

PLAN VIEW

KEY	ITEM
	24" White
	White

Posted Speed Limit (M.P.H.)	L (Ft.)
≤ 30	100
35	100
40	125
45	175
50	250
55	325
60	400
65	475
70	550

GENERAL NOTES:

The railroad crossing pavement markings will be placed symmetrically about the centerline of the railroad crossing. DETAIL A should be used unless the railroad crossing pavement markings are installed in existing grooves that match DETAIL B.

When pavement markings are used, a portion of the RXR symbol will be placed directly opposite of the advance warning sign W10-1.

On multi-lane roads the transverse bands will extend across all approach lanes and individual RXR symbols will be placed in each approach lane.

The railroad crossing pavement markings will consist of all the transverse bands, stop lines, and RXR symbols.

All costs for furnishing and installing the markings, materials, labor, and necessary equipment for the railroad crossing markings will be paid for at the contract unit price per gallon or per each for the type of marking material specified in the plans.

November 19, 2020

Published Date: 2024

**S
D
D
O
T**

PAVEMENT MARKINGS AT RAILROAD CROSSING

PLATE NUMBER
633.10

Sheet 1 of 2

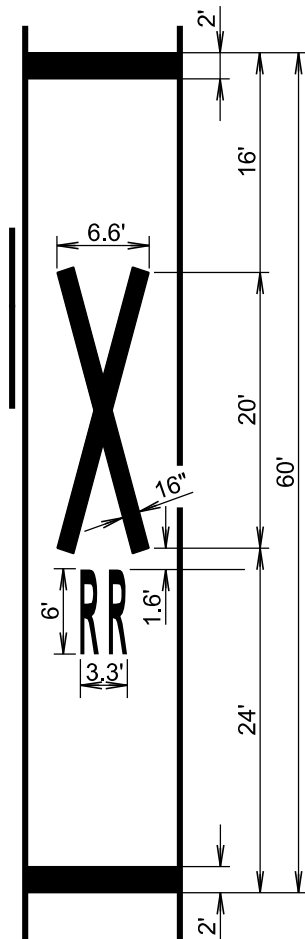

DETAIL A

Width may vary according to lane width.

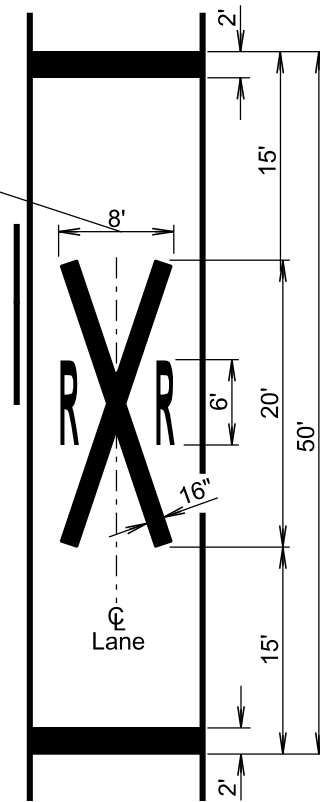

DETAIL B

November 19, 2020

Published Date: 2024

**S
D
D
O
T**

PAVEMENT MARKINGS AT RAILROAD CROSSING

PLATE NUMBER
633.10

Sheet 2 of 2

