

LEGEND

← Direction Of Traffic, Increasing Stationing Or Thru Traffic Side

⊥ Lane line dimensions are shown on the striping plans

The selection and use of this Standard Drawing, while designed in accordance with generally accepted engineering principles and practices, is the sole responsibility of the user and should not be used without first consulting a Registered Professional Engineer.

All materials shall be in accordance with the current Oregon Standard Specifications.	
OREGON STANDARD DRAWINGS	
PAVEMENT MARKING STANDARD DETAIL BLOCKS	
2021	
DATE	REVISION DESCRIPTION
07-2020	Changed Min. widths for CH, TM, TM-40, and TS
CALC. BOOK NO.	SDR DATE
N/A	07-01-2020
TM500	

SA

STRAIGHT ARROW (white)
For arrow proportion details, see current version of Standard Highway Signs

LA

LEFT TURN ARROW (white)
For arrow proportion details, see current version of Standard Highway Signs

RA

RIGHT TURN ARROW (white)
For arrow proportion details, see current version of Standard Highway Signs

LSA

LEFT TURN STRAIGHT ARROW (white)
For arrow proportion details, see current version of Standard Highway Signs

RSA

RIGHT TURN STRAIGHT ARROW (white)
For arrow proportion details, see current version of Standard Highway Signs

RALA

RIGHT TURN LEFT TURN ARROW (white)
For arrow proportion details, see current version of Standard Highway Signs

RSLA

RIGHT TURN STRAIGHT LEFT TURN ARROW (white)
For arrow proportion details, see current version of Standard Highway Signs

E-SA

ELONGATED STRAIGHT ARROW (white)
For arrow proportion details, see current version of Standard Highway Signs

E-LA

ELONGATED LEFT TURN ARROW (white)
For arrow proportion details, see current version of Standard Highway Signs

E-RA

ELONGATED RIGHT TURN ARROW (white)
For arrow proportion details, see current version of Standard Highway Signs

E-LSA

ELONGATED LEFT TURN STRAIGHT ARROW (white)
For arrow proportion details, see current version of Standard Highway Signs

E-RSA

ELONGATED RIGHT TURN STRAIGHT ARROW (white)
For arrow proportion details, see current version of Standard Highway Signs

E-RALA

ELONGATED RIGHT TURN LEFT TURN ARROW (white)
For arrow proportion details, see current version of Standard Highway Signs

E-RSLA

ELONGATED RIGHT TURN STRAIGHT LEFT TURN ARROW (white)
For arrow proportion details, see current version of Standard Highway Signs

F-LA

FISH-HOOK LEFT TURN ARROW (white)
For arrow proportion details, see the current ODOT Traffic Line Manual

F-RALA

FISH-HOOK RIGHT TURN LEFT TURN ARROW (white)
For arrow proportion details, see the current ODOT Traffic Line Manual

F-SA

FISH-HOOK STRAIGHT ARROW (white)
For arrow proportion details, see the current ODOT Traffic Line Manual

F-RSA

FISH-HOOK RIGHT TURN STRAIGHT ARROW (white)
For arrow proportion details, see the current ODOT Traffic Line Manual

F-LSA

FISH-HOOK LEFT TURN STRAIGHT ARROW (white)
For arrow proportion details, see the current ODOT Traffic Line Manual

F-RSLA

FISH-HOOK RIGHT TURN STRAIGHT LEFT TURN ARROW (white)
For arrow proportion details, see the current ODOT Traffic Line Manual

LRA-L

LANE REDUCTION ARROW - LEFT LANE ENDS (white)
For arrow proportion details, see current version of Standard Highway Signs

LRA-R

LANE REDUCTION ARROW - RIGHT LANE ENDS (white)
For arrow proportion details, see current version of Standard Highway Signs

WWA

WRONG-WAY ARROW (white)

General Note:
1. Center pavement markings within the lane width.
2. Arrow and letter dimensions nominal, excluding WWA.

The selection and use of this Standard Drawing, while designed in accordance with generally accepted engineering principles and practices, is the sole responsibility of the user and should not be used without first consulting a Registered Professional Engineer.

All materials shall be in accordance with the current Oregon Standard Specifications.		
OREGON STANDARD DRAWINGS		
PAVEMENT MARKING STANDARD DETAIL BLOCKS		
2021		
DATE	REVISION	DESCRIPTION
07-2020		Some Detail Blocks moved to new Std. Drawing TM504
01-2022		Fish-hook Arrows added, LRA split into LRA-L and LRA-R
01-2022		Corrected bubble callout of LRA-L and typo in LRA-R
CALC. BOOK NO.	N/A	SDR DATE: 01-03-2022
		TM501

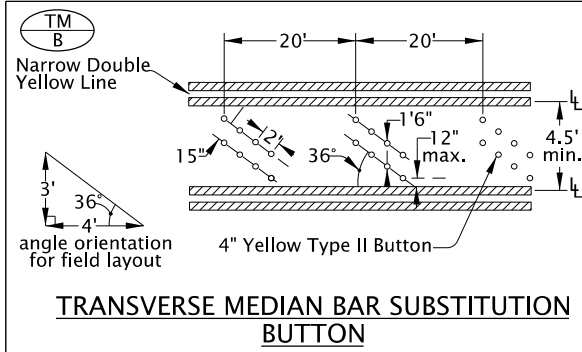

TRANSVERSE MEDIAN BAR SUBSTITUTION BUTTON

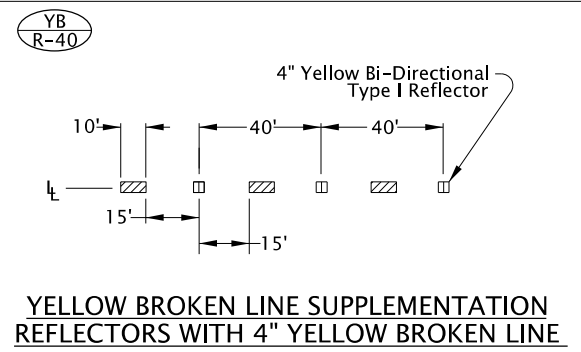

YELLOW BROKEN LINE SUPPLEMENTATION REFLECTORS WITH 4" YELLOW BROKEN LINE

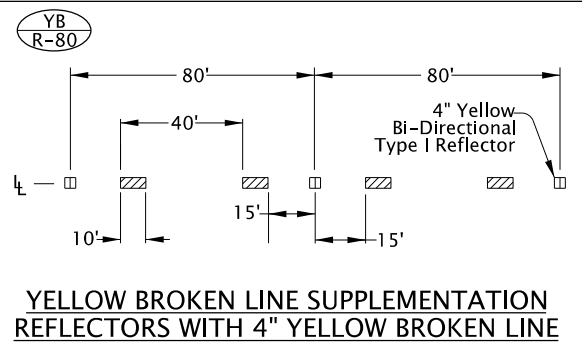

YELLOW BROKEN LINE SUPPLEMENTATION REFLECTORS WITH 4" YELLOW BROKEN LINE

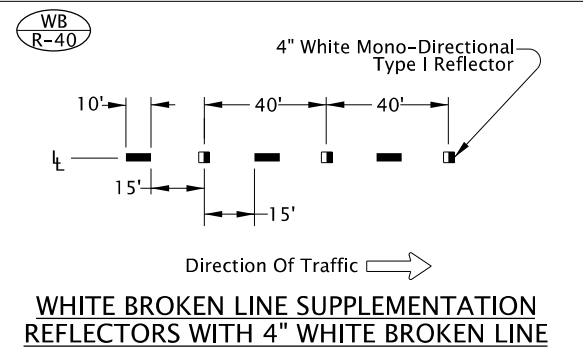

WHITE BROKEN LINE SUPPLEMENTATION REFLECTORS WITH 4" WHITE BROKEN LINE

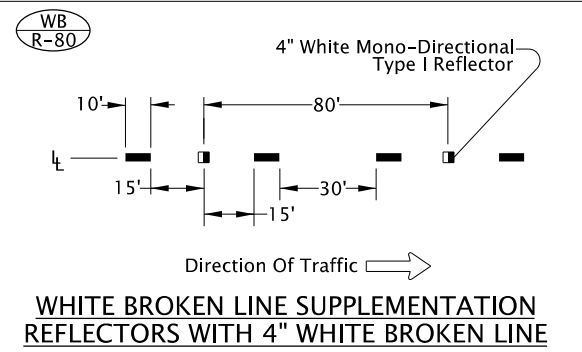

WHITE BROKEN LINE SUPPLEMENTATION REFLECTORS WITH 4" WHITE BROKEN LINE

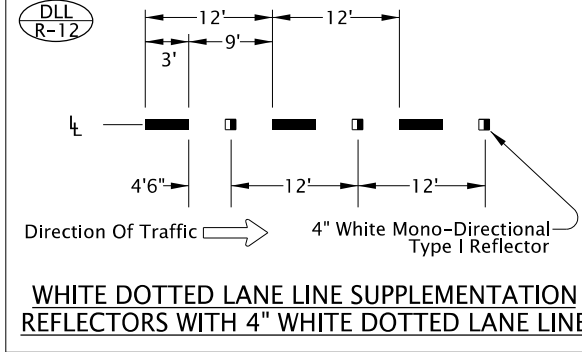

WHITE DOTTED LANE LINE SUPPLEMENTATION REFLECTORS WITH 4" WHITE DOTTED LANE LINE

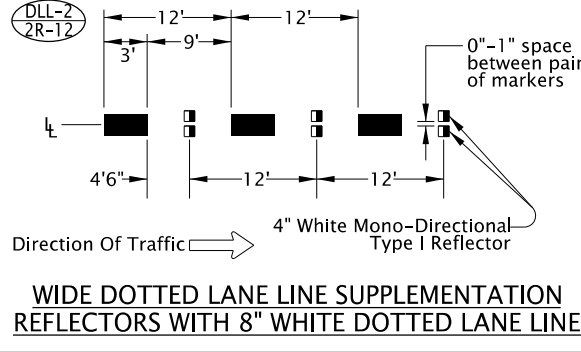

WIDE DOTTED LANE LINE SUPPLEMENTATION REFLECTORS WITH 8" WHITE DOTTED LANE LINE

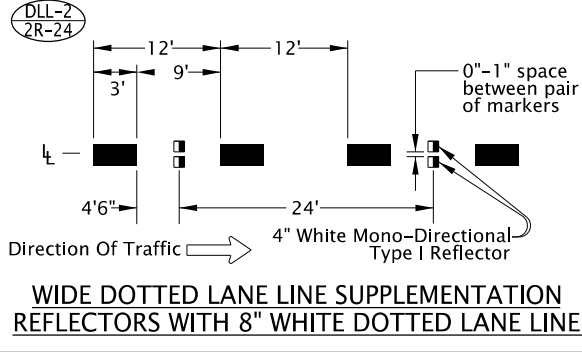

WIDE DOTTED LANE LINE SUPPLEMENTATION REFLECTORS WITH 8" WHITE DOTTED LANE LINE

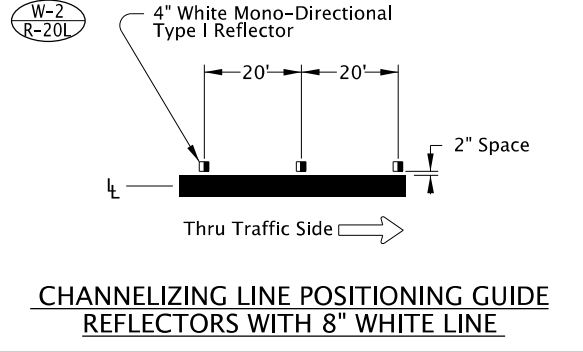

CHANNELIZING LINE POSITIONING GUIDE REFLECTORS WITH 8" WHITE LINE

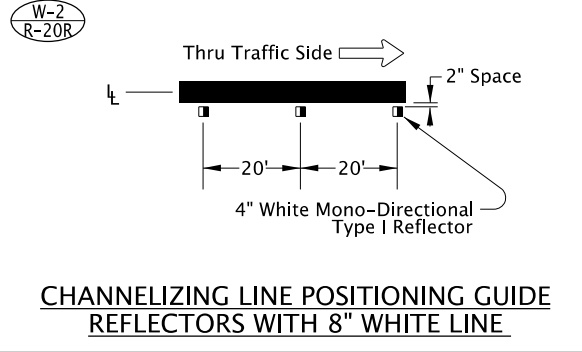

CHANNELIZING LINE POSITIONING GUIDE REFLECTORS WITH 8" WHITE LINE

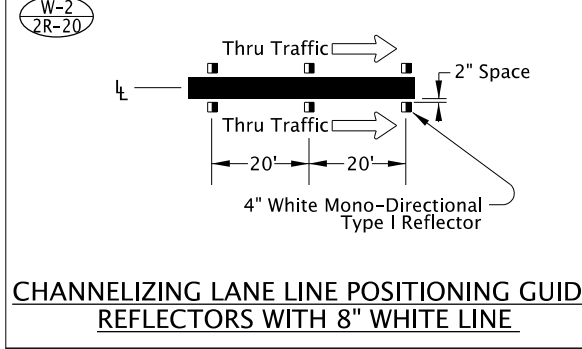

CHANNELIZING LANE LINE POSITIONING GUIDE REFLECTORS WITH 8" WHITE LINE

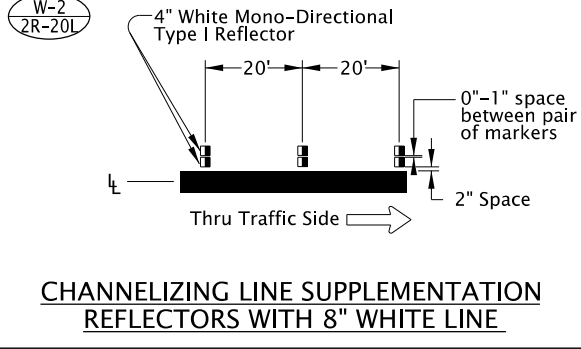

CHANNELIZING LINE SUPPLEMENTATION REFLECTORS WITH 8" WHITE LINE

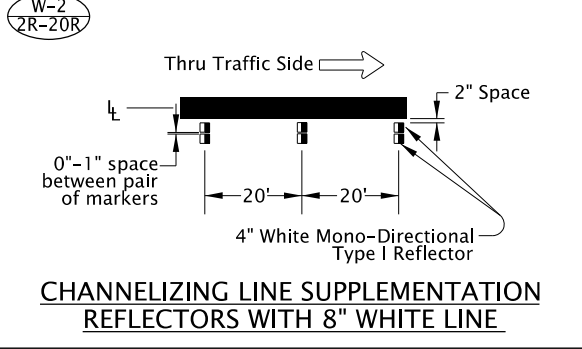

CHANNELIZING LINE SUPPLEMENTATION REFLECTORS WITH 8" WHITE LINE

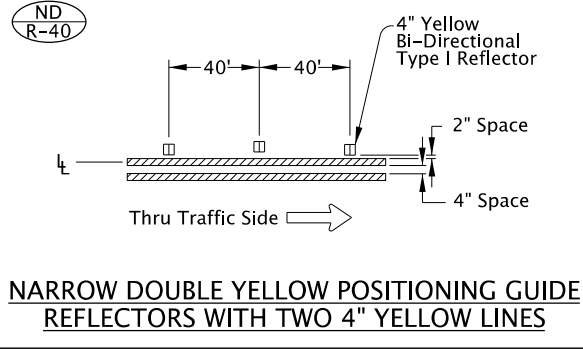

NARROW DOUBLE YELLOW POSITIONING GUIDE REFLECTORS WITH TWO 4" YELLOW LINES

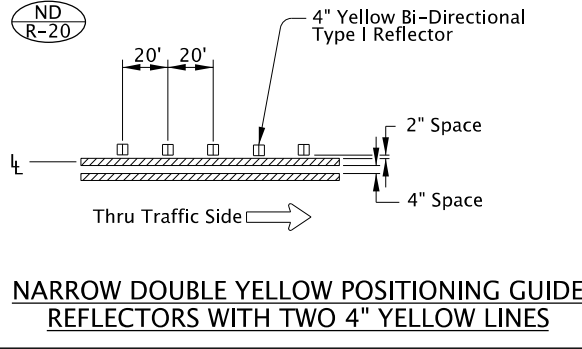

NARROW DOUBLE YELLOW POSITIONING GUIDE REFLECTORS WITH TWO 4" YELLOW LINES

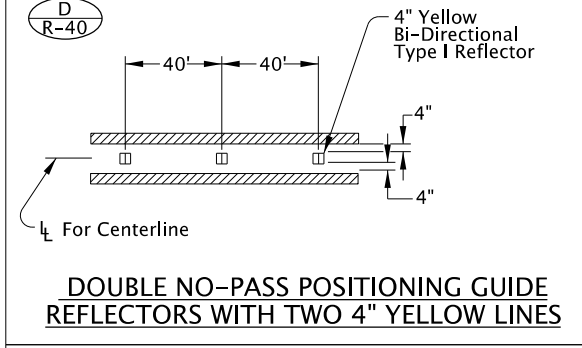

DOUBLE NO-PASS POSITIONING GUIDE REFLECTORS WITH TWO 4" YELLOW LINES

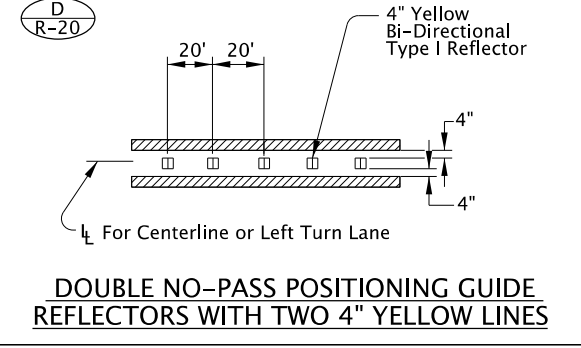

DOUBLE NO-PASS POSITIONING GUIDE REFLECTORS WITH TWO 4" YELLOW LINES

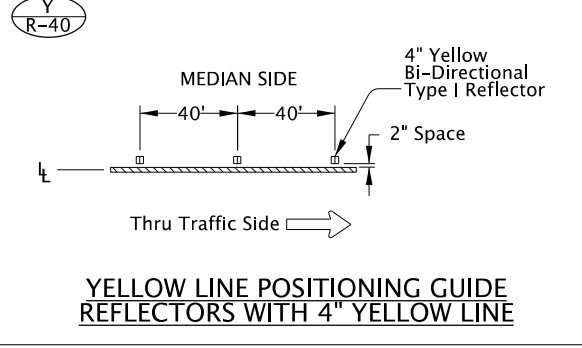

YELLOW LINE POSITIONING GUIDE REFLECTORS WITH 4" YELLOW LINE

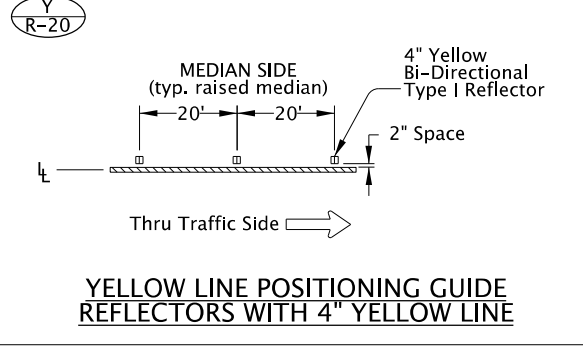

YELLOW LINE POSITIONING GUIDE REFLECTORS WITH 4" YELLOW LINE

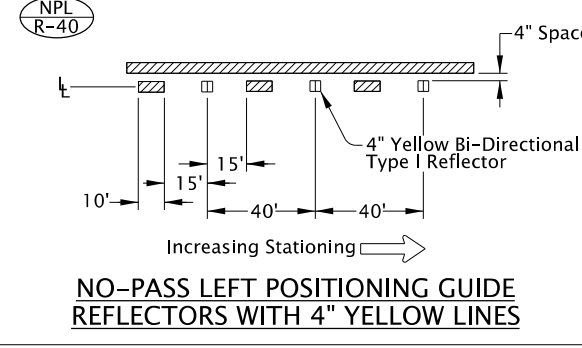

NO-PASS LEFT POSITIONING GUIDE REFLECTORS WITH 4" YELLOW LINES

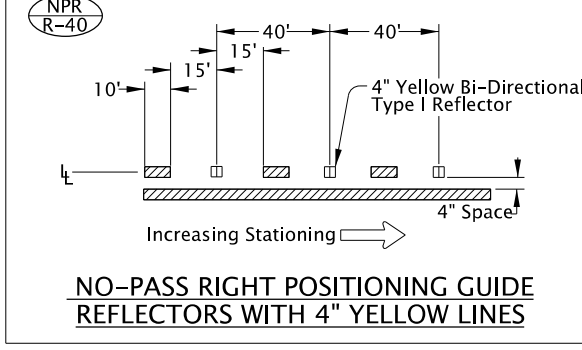

NO-PASS RIGHT POSITIONING GUIDE REFLECTORS WITH 4" YELLOW LINES

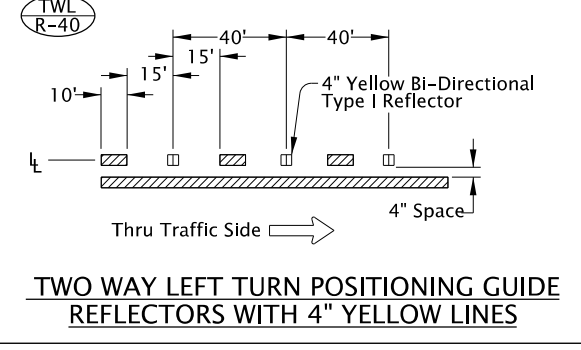

TWO WAY LEFT TURN POSITIONING GUIDE REFLECTORS WITH 4" YELLOW LINES

General note:
1) Surface mount Raised Pavement Markers (RPMs) unless otherwise specified.

- LEGEND**
- ← Direction Of Travel, Increasing Stationing or Thru Traffic Side
 - ⊥ Lane line dimensions are shown on the striping plans
 - Mono-directional crystal white marker reflects white to the left in this symbol
 - Bi-directional yellow marker reflects yellow both left and right in this symbol

The selection and use of this Standard Drawing, while designed in accordance with generally accepted engineering principles and practices, is the sole responsibility of the user and should not be used without first consulting a Registered Professional Engineer.

All materials shall be in accordance with the current Oregon Standard Specifications.		
OREGON STANDARD DRAWINGS		
PAVEMENT MARKING STANDARD DETAIL BLOCKS		
2021		
DATE	REVISION DESCRIPTION	
07-2020	Changed min. width of TM/B from 6' to 4.5'	
01-2022	Removed "LANE" from W-2/R-20R title	
CALC. BOOK NO.	N/A	SDR DATE: 01-03-2022
		TM502

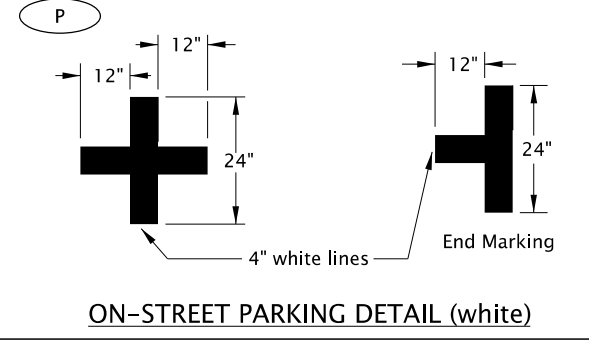
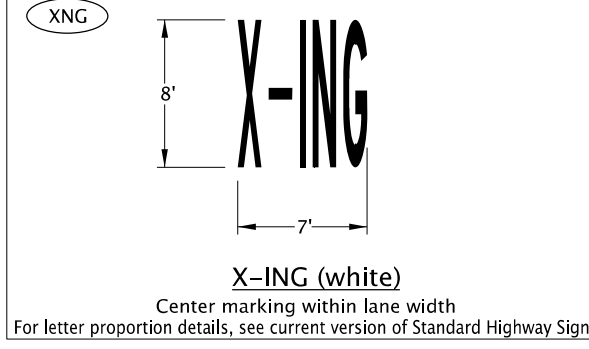
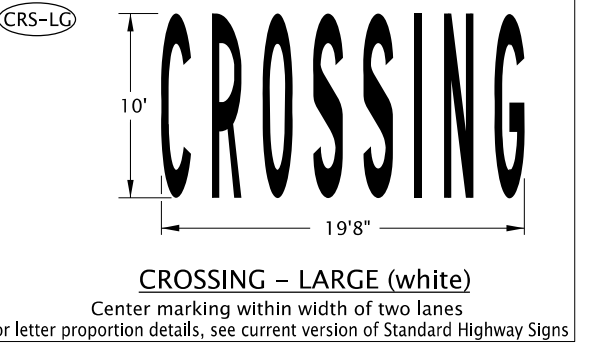
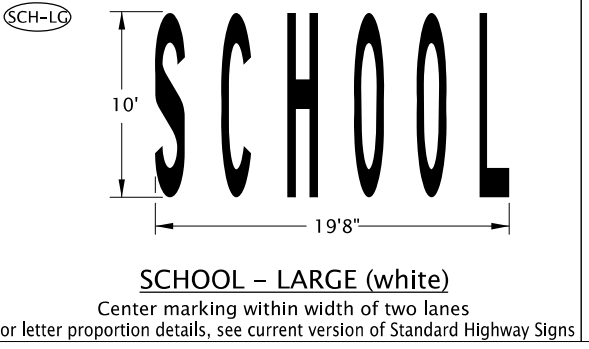
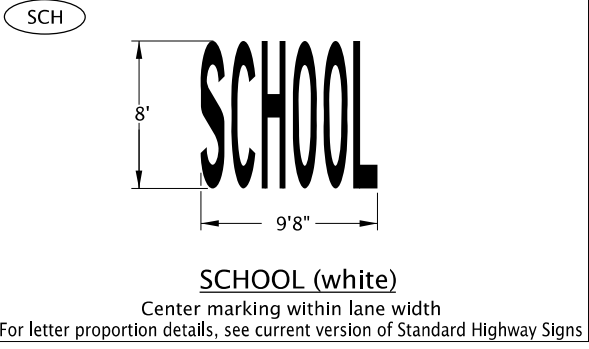
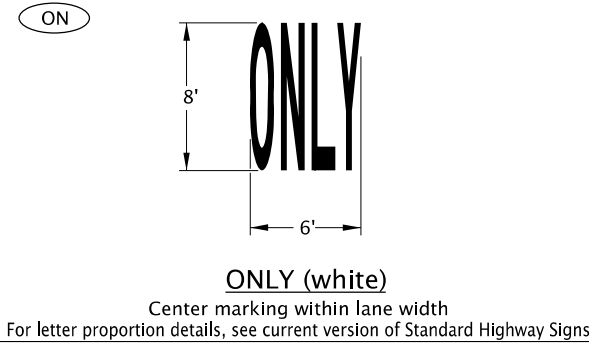
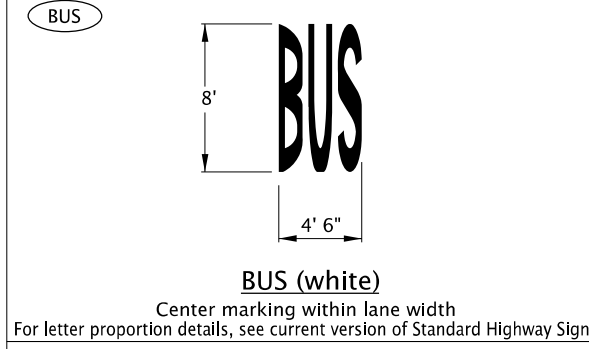
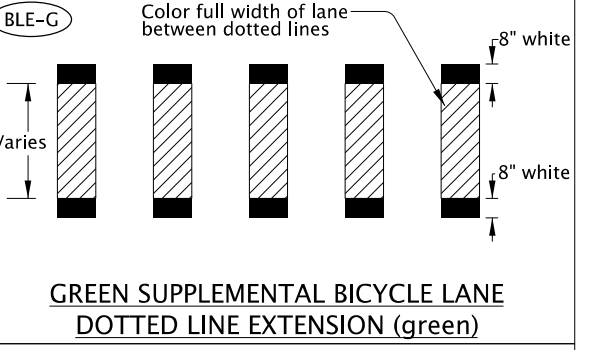
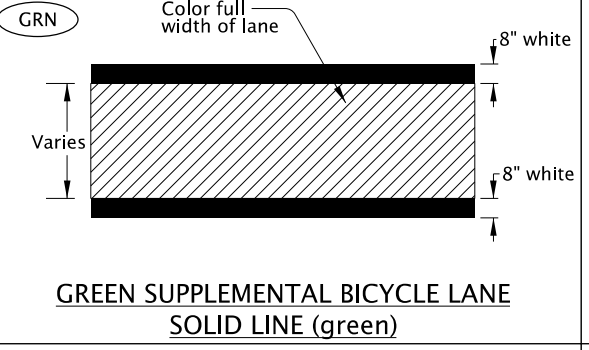
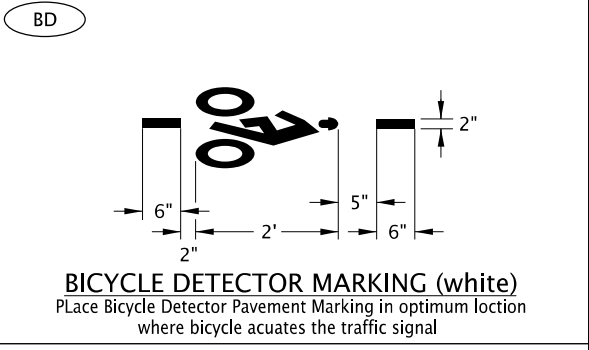
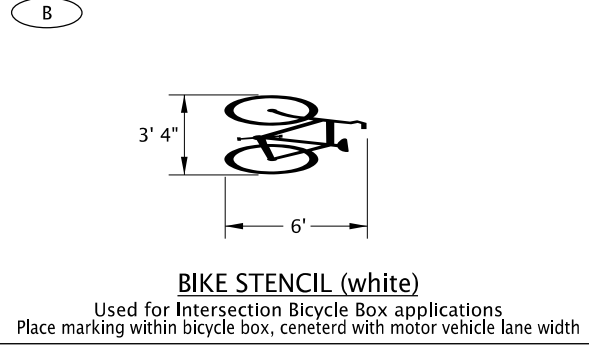
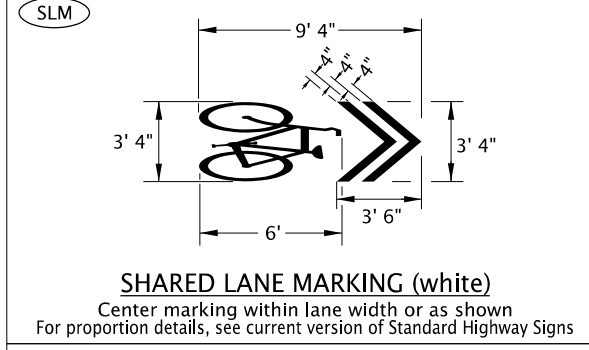
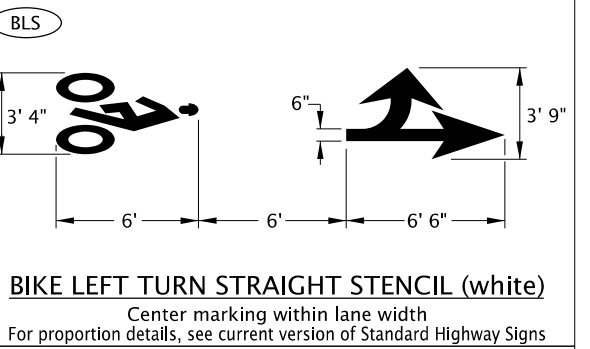
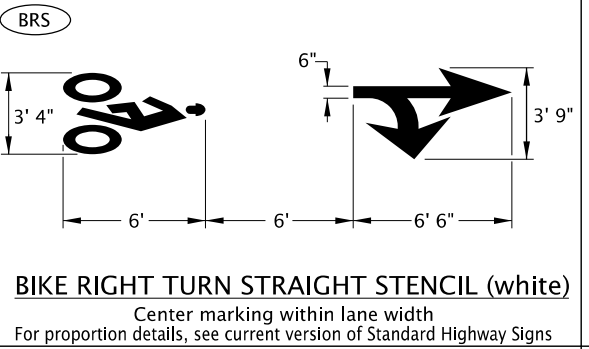
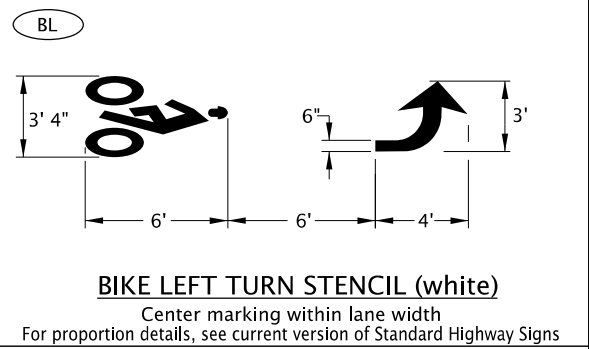
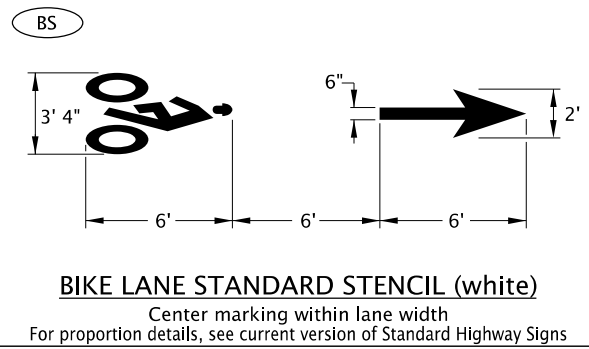
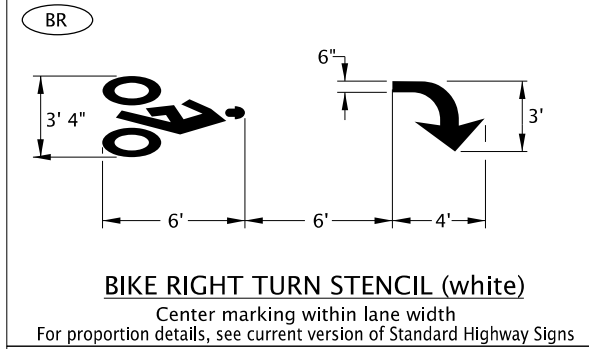
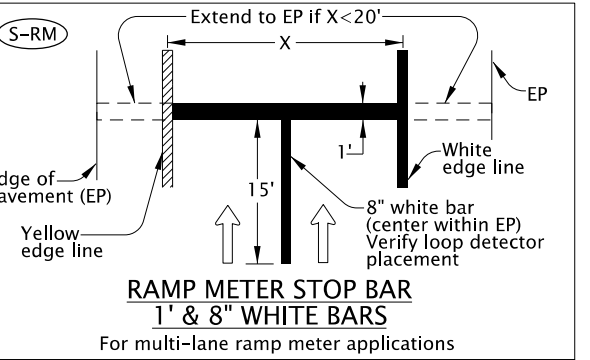
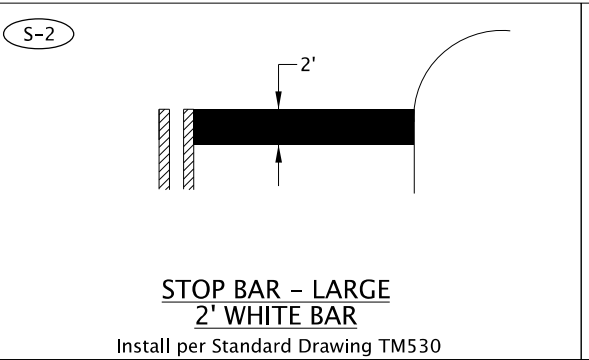
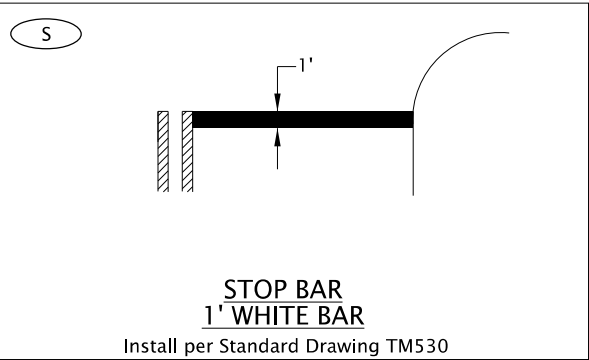
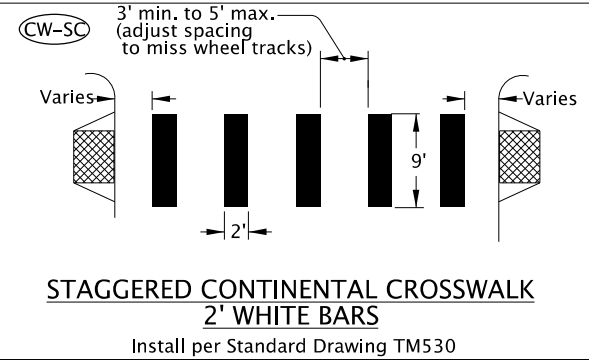
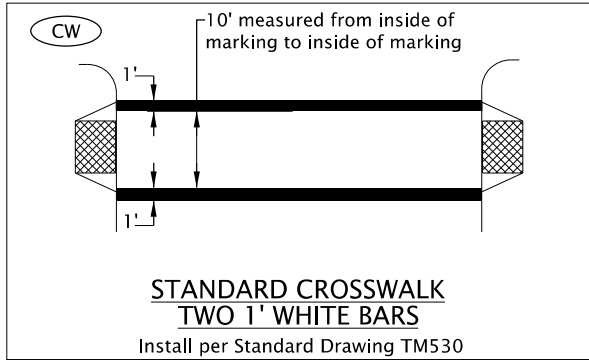

General Note:
1. Arrow, letter, and bike symbol dimensions nominal.

LEGEND
← Direction of Travel

The selection and use of this Standard Drawing, while designed in accordance with generally accepted engineering principles and practices, is the sole responsibility of the user and should not be used without first consulting a Registered Professional Engineer.

All materials shall be in accordance with the current Oregon Standard Specifications.

OREGON STANDARD DRAWINGS

**PAVEMENT MARKING
STANDARD DETAIL BLOCKS**

2021

DATE	REVISION	DESCRIPTION
07-2022	Added note for measurement of Standard Crosswalk	

CALC. BOOK NO. - - - N/A - - - SDR DATE - 07-08-2022 - **TM503**

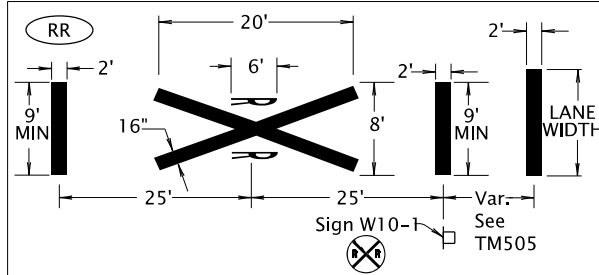

RAILROAD CROSSING (white)

Install per ODOT Rail Crossing Order or as shown.
For letter proportion details, see current version of Standard Highway Signs

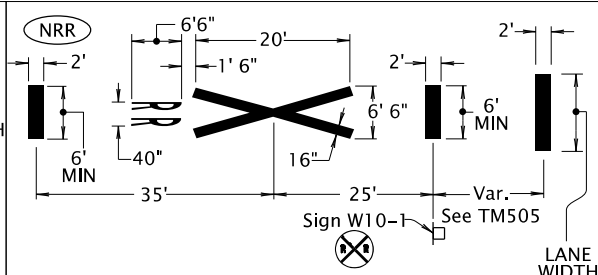

NARROW RAILROAD CROSSING (white)

Install per ODOT Rail Crossing Order or as shown.
For letter proportion details, see current version of Standard Highway Signs

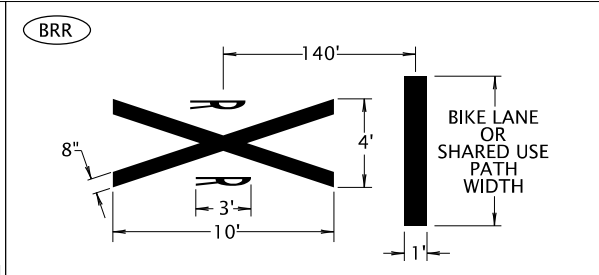

BICYCLE RAILROAD CROSSING (white)

Install per ODOT Rail Crossing Order or as shown.
For letter proportion details, see current version of Standard Highway Signs

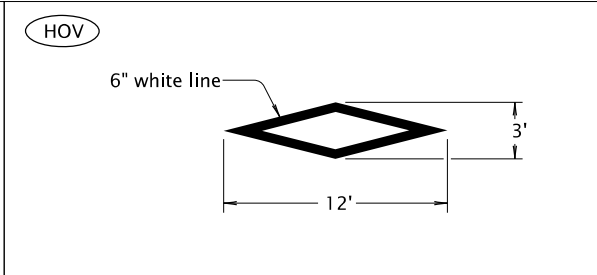

**HIGH-OCCUPANCY VEHICLE
DIAMOND DETAIL (white)**

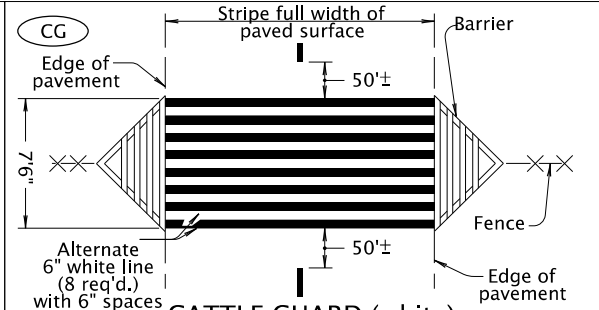

CATTLE GUARD (white)

For barrier and fence details, see Std. Dwg. RD110

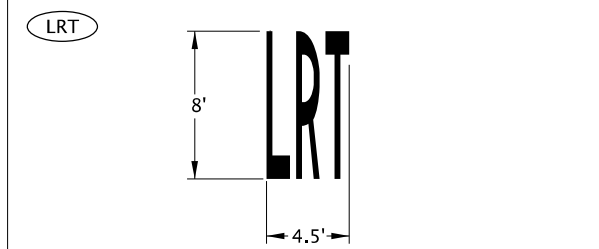

LIGHT RAIL TRANSIT (white)

Center marking within lane width
For letter proportion details, see current version of Standard Highway Signs

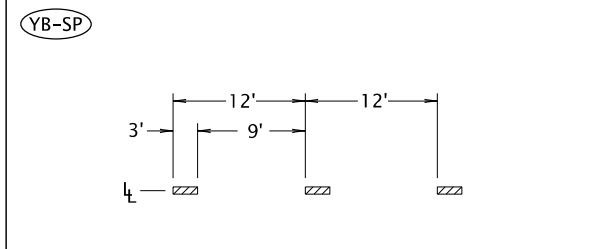

4" YELLOW SHARED PATH BROKEN LINE

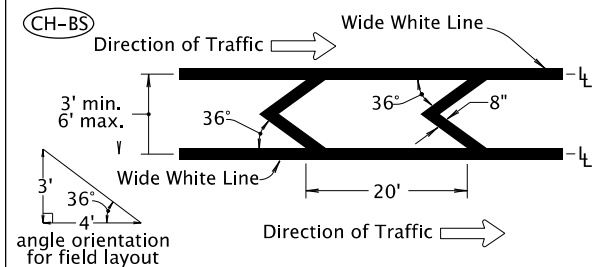

**CHEVRON BARS - BUFFER SPACE
8" WHITE BARS AT 20' SPACING**

General Note:

1. Center pavement markings within the lane width.
2. Arrow and letter dimensions nominal, excluding WWA.

← Direction Of Traffic, Increasing Stationing
Or Thru Traffic Side

The selection and use of this Standard Drawing, while designed in accordance with generally accepted engineering principles and practices, is the sole responsibility of the user and should not be used without first consulting a Registered Professional Engineer.

All materials shall be in accordance with the current Oregon Standard Specifications.

OREGON STANDARD DRAWINGS

**PAVEMENT MARKING
STANDARD DETAIL BLOCKS**

2021

DATE	REVISION	DESCRIPTION
07-2020		New Drawing for additional Detail Blocks
CALC. BOOK NO.	N/A	SDR DATE

TM504