

BIKE LANE LEGEND DETAIL

SEE CALTRANS STANDARD PLAN A24A AND A24D FOR PAVEMENT MARKING WORDS AND ARROW.

BIKE LANE LEGEND

TYPICAL LOCATIONS:

- 10' AFTER START OF BIKE LANE AT INTERSECTION
- 10' AFTER START OF BIKE LANE ALONG RIGHT TURN LANE
- BEFORE 39A STRIPE AT APPROACH TO A TRAFFIC SIGNAL WITHOUT RIGHT TURN LANE

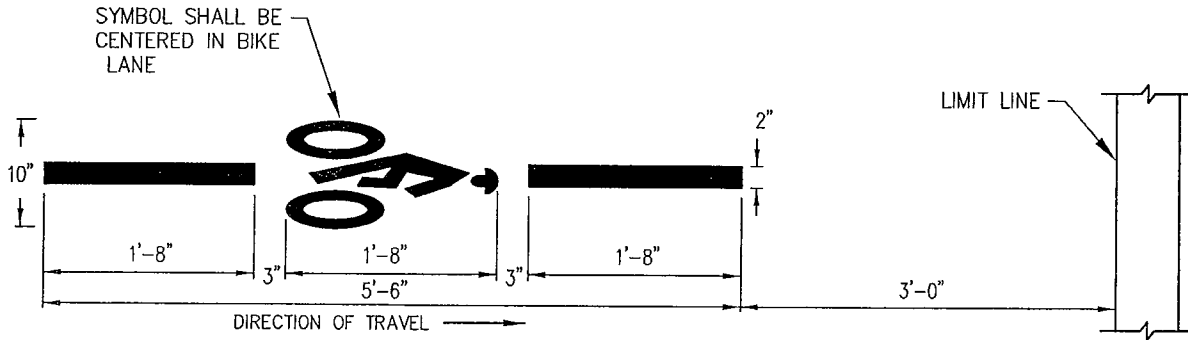

BICYCLE LOOP DETECTOR SYMBOL

SEE CALTRANS STANDARD PLAN A24C FOR PAVEMENT MARKINGS SYMBOLS.

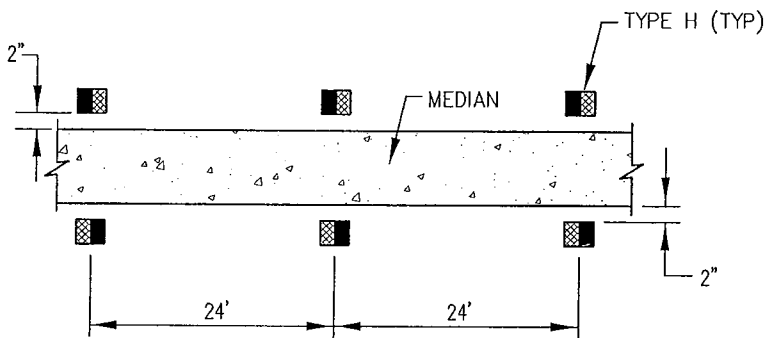

DETAIL MODIFIELD 26 - FOR USE ADJACENT TO MEDIANS

SEE CALTRANS STANDARD PLAN A20B FOR PAVEMENT MARKER TYPE.

CHIEF, DEPT. OF TRANSPORTATION

**COUNTY OF SACRAMENTO
MUNICIPAL SERVICES AGENCY**

**STRIPING AND PAVEMENT
MARKING DETAILS**

SCALE: NONE
DATE: 03/30/2009
DRAWN BY: TRU P.

4-77