

Gallon Counter

3B0122A

EN

Replacement gallon counter for LineLazer 200HS/DC/MMA and LineLazer 250SPS/DC/MMA. For professional use only.

Kit Number: 287186



Important Safety Instructions

Read all warnings and instructions in this manual and in the striper manuals before using the equipment. Be familiar with the proper control and usage of the equipment. Save these instructions.

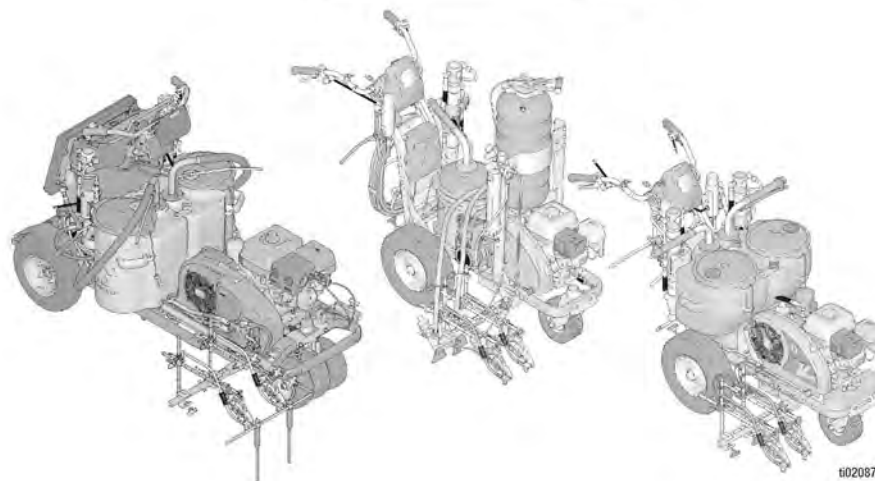
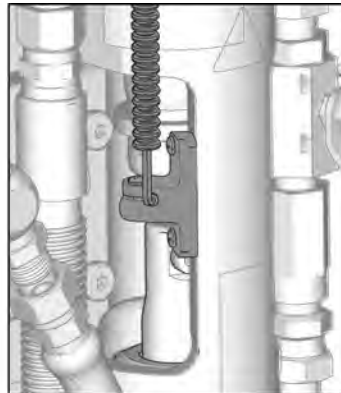

Contents

Related Manuals	2	Removing Existing Gallon Counter	5
Safety Symbols	3	Recycling and Disposal	7
General Warnings	4	End of Product Life.....	7
200HS/DC/MMA and 250SPS/DC/MMA Magnet Replacment Kit 287186	5	Graco Standard Warranty	8



Related Manuals



Find English manuals and any available translations at www.graco.com.

English Manual Number	Description
3A3394	LineLazer V 250SPS and 250DC Self-Propelled Line Striper, Repair and Parts
3A3426	LineLazer V 200HS Airless Line Stripers, Operation
3A6466	LineLazer V 200MMA 1:1 Airless Line Stripers, Operation, Repair, Parts

Safety Symbols

The following safety symbols appear throughout this manual and on warning labels. Read the table below to understand what each symbol means.

Symbol	Meaning
	Burn Hazard
	Moving Parts Hazard

Symbol	Meaning
	Follow Pressure Relief Procedure
	Wear Personal Protective Equipment







Safety Alert Symbol

This symbol indicates: Attention! Become Alert! Look for this symbol throughout the manual to indicate important safety messages.

General Warnings

The following warnings apply throughout this manual. Read, understand, and follow the warnings before using this equipment. Failure to follow these warnings can result in serious injury.

 WARNING	
 	<p>MOVING PARTS HAZARD Moving parts can pinch, cut or amputate fingers and other body parts.</p> <ul style="list-style-type: none">• Keep clear of moving parts.• Do not operate equipment with protective guards or covers removed.• Equipment can start without warning. Before checking, moving, or servicing equipment, follow the Pressure Relief Procedure and disconnect all power sources.
	<p>BURN HAZARD Equipment surfaces and fluid that is heated can become very hot during operation. To avoid severe burns:</p> <ul style="list-style-type: none">• Do not touch hot fluid or equipment.
	<p>PERSONAL PROTECTIVE EQUIPMENT Wear appropriate protective equipment when in the work area to help prevent serious injury, including eye injury, hearing loss, inhalation of toxic fumes, and burns. Protective equipment includes but is not limited to:</p> <ul style="list-style-type: none">• Protective eyewear, and hearing protection.• Respirators, protective clothing, and gloves as recommended by the fluid and solvent manufacturer.

200HS/DC/MMA and 250SPS/DC/MMA Magnet Replacement Kit 287186

Removing Existing Gallon Counter



This equipment stays pressurized until pressure is manually relieved. To help prevent serious injury from moving parts, follow the Pressure Relief Procedure when you stop spraying and before cleaning, checking, or servicing the equipment.

1. Allow the sprayer to cool.
2. Follow the **Pressure Relief Procedure** in your LineLazer manual.
3. Turn unit OFF.
4. Close hydraulic valve (AA).
5. Remove shield (BB).

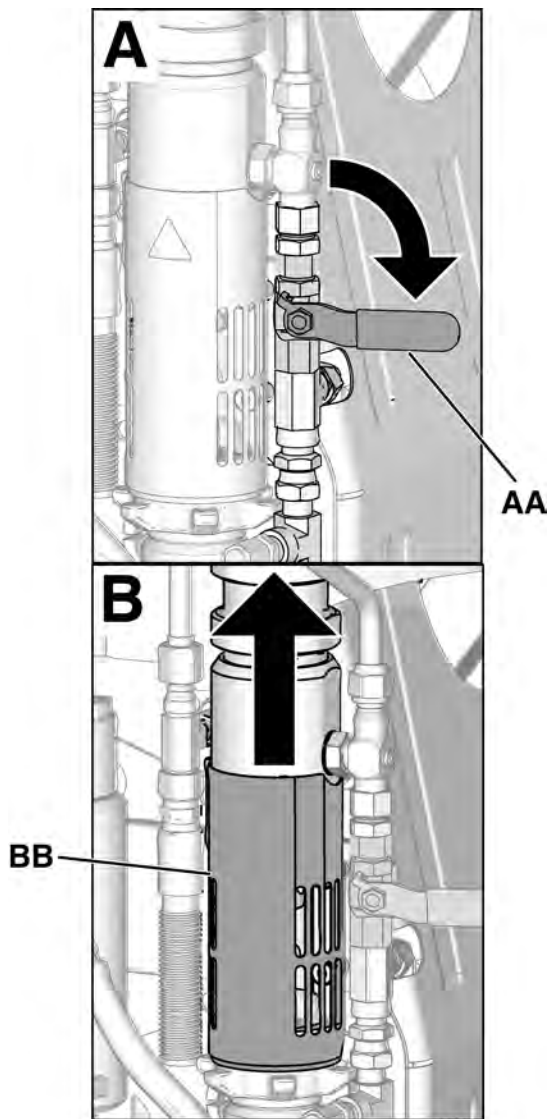

Removing Existing Gallon Counter

- Remove two screws (CC) securing existing gallon counter (DD). Remove gallon counter.

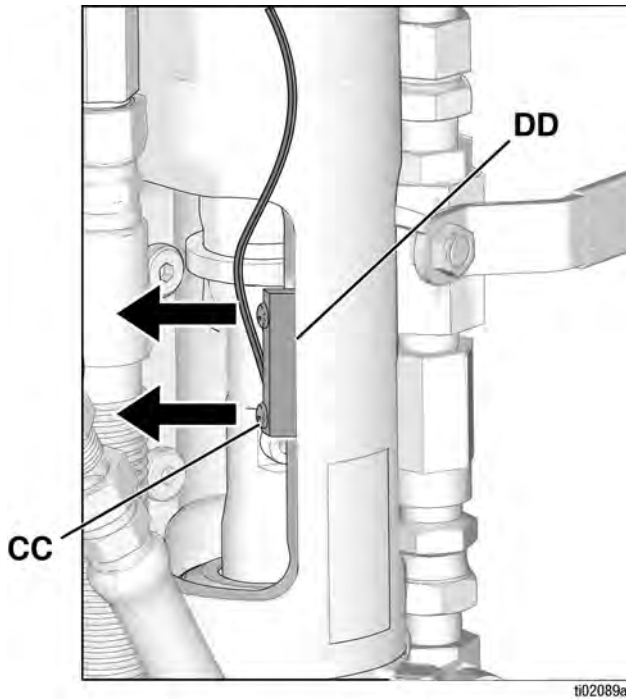

- Install two screws to secure gallon counter bracket (EE) to pump housing. Ensure screw (GG) is facing upwards.

- Route new wiring (HH) along path of old wiring. Disconnect existing gallon counter connector and connect replacement gallon counter.

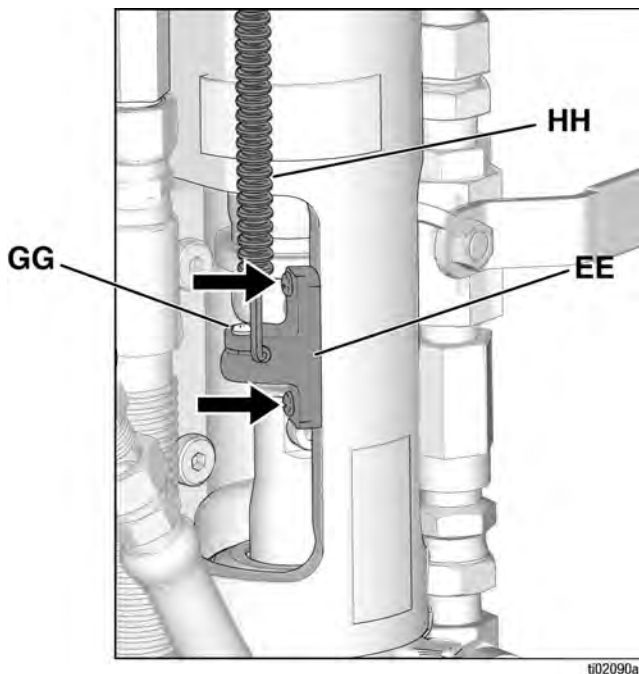

- Cut foam (II) into two equal pieces. Remove backing and adhere in approximate locations shown.

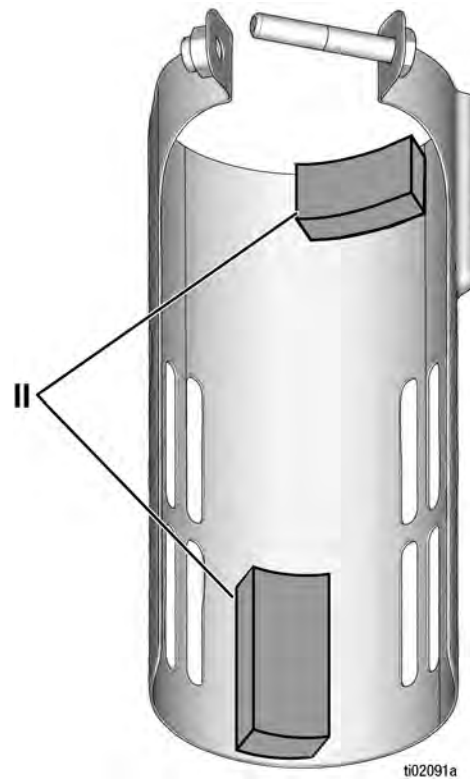

- Reinstall shield (BB). Ensure clearance between gallon counter wires and shield.

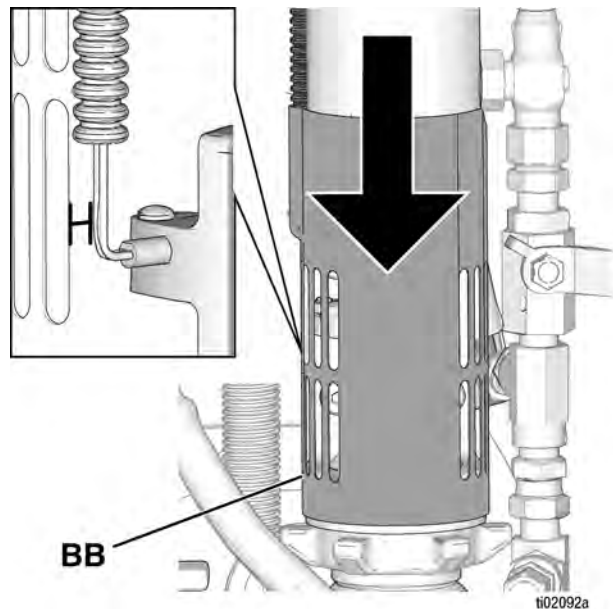

Recycling and Disposal

End of Product Life

At the end of a product's useful life, recycle it in a responsible manner.

California Proposition 65

CALIFORNIA RESIDENTS

 **WARNING:** Cancer and reproductive harm – www.P65warnings.ca.gov.

Graco Standard Warranty

Graco warrants all equipment referenced in this document which is manufactured by Graco and bearing its name to be free from defects in material and workmanship on the date of sale to the original purchaser for use. With the exception of any special, extended, or limited warranty published by Graco, Graco will, for a period of twelve months from the date of sale, repair or replace any part of the equipment determined by Graco to be defective. This warranty applies only when the equipment is installed, operated and maintained in accordance with Graco's written recommendations.

This warranty does not cover, and Graco shall not be liable for general wear and tear, or any malfunction, damage or wear caused by faulty installation, misapplication, abrasion, corrosion, inadequate or improper maintenance, negligence, accident, tampering, or substitution of non-Graco component parts. Nor shall Graco be liable for malfunction, damage or wear caused by the incompatibility of Graco equipment with structures, accessories, equipment or materials not supplied by Graco, or the improper design, manufacture, installation, operation or maintenance of structures, accessories, equipment or materials not supplied by Graco.

This warranty is conditioned upon the prepaid return of the equipment claimed to be defective to an authorized Graco distributor for verification of the claimed defect. If the claimed defect is verified, Graco will repair or replace free of charge any defective parts. The equipment will be returned to the original purchaser transportation prepaid. If inspection of the equipment does not disclose any defect in material or workmanship, repairs will be made at a reasonable charge, which charges may include the costs of parts, labor, and transportation.

THIS WARRANTY IS EXCLUSIVE, AND IS IN LIEU OF ANY OTHER WARRANTIES, EXPRESS OR IMPLIED, INCLUDING BUT NOT LIMITED TO WARRANTY OF MERCHANTABILITY OR WARRANTY OF FITNESS FOR A PARTICULAR PURPOSE.

Graco's sole obligation and buyer's sole remedy for any breach of warranty shall be as set forth above. The buyer agrees that no other remedy (including, but not limited to, incidental or consequential damages for lost profits, lost sales, injury to person or property, or any other incidental or consequential loss) shall be available. Any action for breach of warranty must be brought within two (2) years of the date of sale.

GRACO MAKES NO WARRANTY, AND DISCLAIMS ALL IMPLIED WARRANTIES OF MERCHANTABILITY AND FITNESS FOR A PARTICULAR PURPOSE, IN CONNECTION WITH ACCESSORIES, EQUIPMENT, MATERIALS OR COMPONENTS SOLD BUT NOT MANUFACTURED BY GRACO. These items sold, but not manufactured by Graco (such as electric motors, switches, hose, etc.), are subject to the warranty, if any, of their manufacturer. Graco will provide purchaser with reasonable assistance in making any claim for breach of these warranties.

In no event will Graco be liable for indirect, incidental, special or consequential damages resulting from Graco supplying equipment hereunder, or the furnishing, performance, or use of any products or other goods sold hereto, whether due to a breach of contract, breach of warranty, the negligence of Graco, or otherwise.

FOR GRACO CANADA CUSTOMERS

The Parties acknowledge that they have required that the present document, as well as all documents, notices and legal proceedings entered into, given or instituted pursuant hereto or relating directly or indirectly hereto, be drawn up in English. Les parties reconnaissent avoir convenu que la rédaction du présente document sera en Anglais, ainsi que tous documents, avis et procédures judiciaires exécutés, donnés ou intentés, à la suite de ou en rapport, directement ou indirectement, avec les procédures concernées.

Graco Information

TO PLACE AN ORDER, find us at rae-prostores.com or call us [1-877-275-7550](tel:1-877-275-7550).



All written and visual data contained in this document reflects the latest product information available at the time of publication. Graco reserves the right to make changes at any time without notice.

Original instructions. This manual contains English. MM 3B0122

Graco Headquarters: Minneapolis

International Offices: Belgium, China, Japan, Korea

GRACO INC. AND SUBSIDIARIES • P.O. BOX 1441 • MINNEAPOLIS MN 55440-1441 • USA
Copyright 2024, Graco Inc. All Graco manufacturing locations are registered to ISO 9001.

www.graco.com
Revision A, April 2024