

# GrindLazer™

3A5919C  
EN

**For removal of materials from flat horizontal concrete and asphalt surfaces. For professional use only.**

**Model 25M992 - Forward Cut**

GrindLazer HP DC89 G (270 cc / 9 hp)

**Model 25M993 - Forward Cut**

GrindLazer HP DC1013 G (390 cc / 13 hp)

**Model 25M994 - Reverse Up-Cut (Must be used with LineDriver™)**

GrindLazer HP DC1021 G (627 cc / 21 hp Electric Start)

**Model 25N658 - Forward Cut**

GrindLazer HP DC1013 G DCS (390 cc / 13 hp Electric Start)

**Model 25N659 - Reverse Up-Cut (Must be used with LineDriver™)**

GrindLazer HP DC1021 G DCS (627 cc / 21 hp Electric Start)

**Related Manuals:**

Repair - 3A5919

Parts - 3A5929

LineDriver Operation - 312540

LineDriver ES Operation, Repair, Parts - 3A6623



**IMPORTANT SAFETY INSTRUCTIONS**

Read all warnings and instructions in this manual and in the Operation and Parts Manuals before using the equipment. Be familiar with the controls and the proper usage of the equipment. Save all instructions.

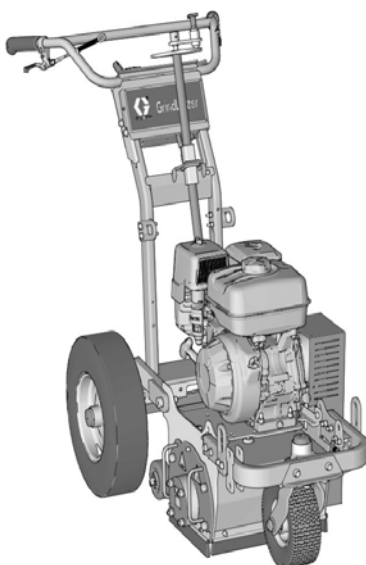

25M992 / 25M993

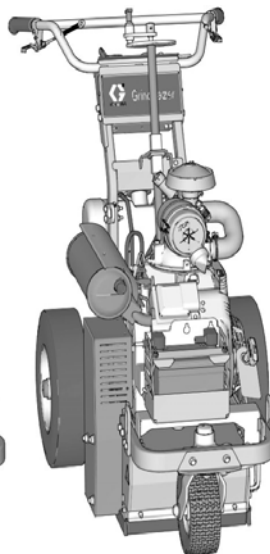

25M994

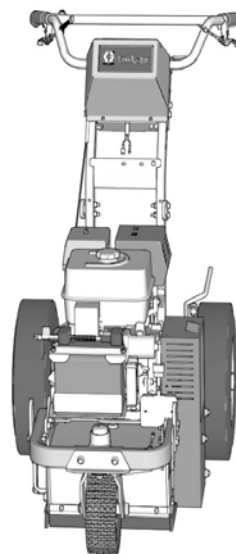

25N658

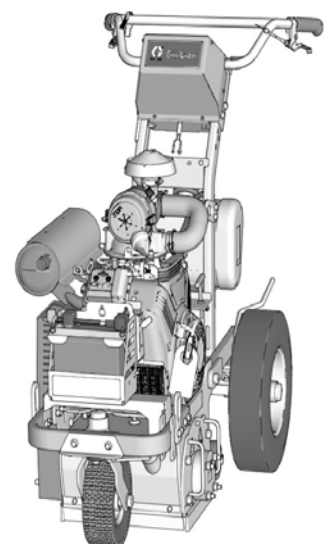

25N659

t135649a

*(Drums, cutters, and LineDriver™ sold separately)*

















# Contents

<b>Warnings</b> .....	<b>3</b>	<b>Drive Bearing Assembly Replacement</b> .....	<b>16</b>
Battery Disposal .....	4	Door Bearing Assembly Removal .....	16
<b>Component Identification</b> .....	<b>5</b>	Door Bearing Assembly Installation .....	16
<b>Component Identification (DCS Models)</b> .....	<b>6</b>	Drive Bearing Assembly Removal .....	17
<b>Drum Replacement</b> .....	<b>7</b>	Drive Bearing Assembly Installation .....	18
<b>Cutter Replacement</b> .....	<b>8</b>	Sheave Installation .....	18
Diamond Blades .....	10	<b>Troubleshooting</b> .....	<b>19</b>
<b>Belt Replacement</b> .....	<b>11</b>	DCS Models only .....	20
<b>Clutch Replacement</b> .....	<b>13</b>	DCS Error Codes .....	21
<b>Pulley Replacement</b> .....	<b>14</b>	DCS Actuator Rod Does Not Move .....	22
<b>Brush Replacement</b> .....	<b>15</b>	<b>Wiring Diagram</b> .....	<b>23</b>
		DCS System .....	23
		DCS Control Box .....	24
		<b>Technical Data</b> .....	<b>25</b>
		<b>Graco Standard Warranty</b> .....	<b>27</b>

# Warnings

The following warnings are for the setup, use, grounding, maintenance, and repair of this equipment. The exclamation point symbol alerts you to a general warning and the hazard symbols refer to procedure-specific risks. When these symbols appear in the body of this manual or on warning labels, refer back to these Warnings. Product-specific hazard symbols and warnings not covered in this section may appear throughout the body of this manual where applicable.

 <h2 style="margin: 0;">WARNING</h2>	
 	<p><b>DUST AND DEBRIS HAZARD</b></p> <p>Grinding concrete and other surfaces with this equipment can create dust that contains hazardous substances. Grinding can also create flying debris.</p> <p>To reduce the risk of serious injury:</p> <ul style="list-style-type: none"> <li>• Control the dust to meet all applicable workplace regulations.</li> <li>• Wear protective eye wear and a properly fit-tested and government approved respirator suitable for the dust conditions.</li> <li>• Use equipment only in a well-ventilated area.</li> <li>• Grinding equipment must be used only by trained personnel who understand the applicable workplace regulations.</li> </ul>
 	<p><b>ENTANGLEMENT AND ROTATING PARTS HAZARD</b></p> <p>Rotating parts can cut or amputate fingers and other body parts.</p> <ul style="list-style-type: none"> <li>• Keep clear of rotating parts.</li> <li>• Do not operate equipment with protective guards or covers removed.</li> <li>• Do not wear loose clothing, jewelry or long hair while operating equipment.</li> <li>• Before checking, moving, or servicing equipment, disable power supply.</li> </ul>
	<p><b>BURN HAZARD</b></p> <p>Cutters and engine can become very hot during operation. To avoid severe burns, do not touch hot equipment. Wait until equipment has cooled completely.</p>
	<p><b>EQUIPMENT MISUSE HAZARD</b></p> <p>Misuse can cause death or serious injury.</p> <ul style="list-style-type: none"> <li>• Do not operate the unit when fatigued or under the influence of drugs or alcohol.</li> <li>• Do not leave the work area while equipment is energized. Turn off all equipment when equipment is not in use.</li> <li>• Check equipment daily. Repair or replace worn or damaged parts immediately with genuine manufacturer's replacement parts only.</li> <li>• Do not alter or modify equipment.</li> <li>• Use equipment only for its intended purpose. Call your distributor for information.</li> <li>• Keep children and animals away from work area.</li> <li>• Comply with all applicable safety regulations.</li> <li>• Maintain a safe operating distance from other people in the work area.</li> <li>• Avoid any pipes, columns, openings, or any other objects protruding from work surface.</li> </ul>
 	<p><b>PERSONAL PROTECTIVE EQUIPMENT</b></p> <p>You must wear appropriate protective equipment when operating, servicing, or when in the operating area of the equipment to help protect you from serious injury, including eye injury, inhalation of dust or chemicals, burns, and hearing loss. This equipment includes but is not limited to:</p> <ul style="list-style-type: none"> <li>• Protective eye wear.</li> <li>• Protective shoes.</li> <li>• Gloves.</li> <li>• Hearing protection.</li> <li>• Properly fit-tested and government approved respirator suitable for the dust conditions.</li> </ul>

 <h1 style="margin: 0;">WARNING</h1>	
 	<p><b>FIRE AND EXPLOSION HAZARD</b></p> <p>Flammable fumes, such as solvent and paint fumes, in <b>work area</b> can ignite or explode. To help prevent fire and explosion:</p> <ul style="list-style-type: none"> <li>• Use equipment only in well ventilated area.</li> <li>• Do not fill fuel tank while engine is running or hot; shut off engine and let it cool. Fuel is flammable and can ignite or explode if spilled on hot surface.</li> <li>• Keep work area free of debris, including solvent, rags and gasoline.</li> <li>• Keep a fire extinguisher in work area.</li> </ul>
	<p><b>CARBON MONOXIDE HAZARD</b></p> <p>Exhaust contains poisonous carbon monoxide, which is colorless and odorless. Breathing carbon monoxide can cause death.</p> <ul style="list-style-type: none"> <li>• Do not operate in an enclosed area.</li> </ul>
	<p><b>BATTERY HAZARD</b></p> <p>Lead-acid batteries produce explosive gases and contain sulfuric acid that can cause severe burns. To avoid sparks and injury when handling or working with a lead-acid battery:</p> <ul style="list-style-type: none"> <li>• Read and follow the battery manufacturer's warnings.</li> <li>• Exercise caution when working with metallic tools or conductors to prevent short circuits and sparks.</li> <li>• Keep all sparks, flames, and cigarettes away from batteries.</li> <li>• Always wear protective eyewear and protective equipment for face, hands, and body.</li> <li>• If you have direct contact with battery fluid, flush with water and consult a physician immediately.</li> <li>• Installation and maintenance must be performed by knowledgeable personnel only.</li> </ul>
	<p><b>CALIFORNIA PROPOSITION 65</b></p> <p>The engine exhaust from this product contains a chemical known to the State of California to cause cancer, birth defects or other reproductive harm.</p> <p>This product contains a chemical known to the State of California to cause cancer, birth defects or other reproductive harm. Wash hands after handling.</p>

## Battery Disposal

Do not place batteries in the trash. Recycle batteries according to local regulations. In the USA and Canada call 1-800-822-8837 to find recycling location or go to [www.call2recycle.org](http://www.call2recycle.org).

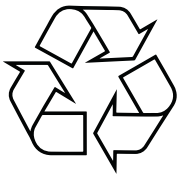

# Component Identification

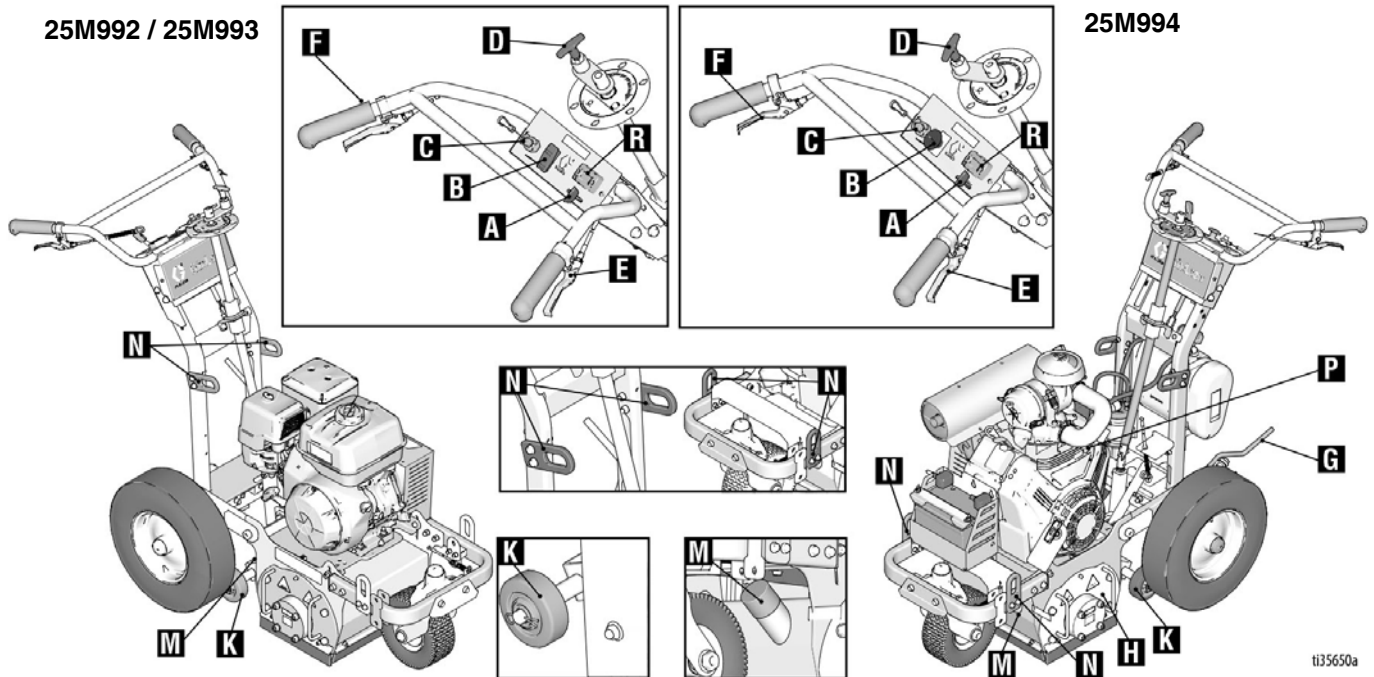



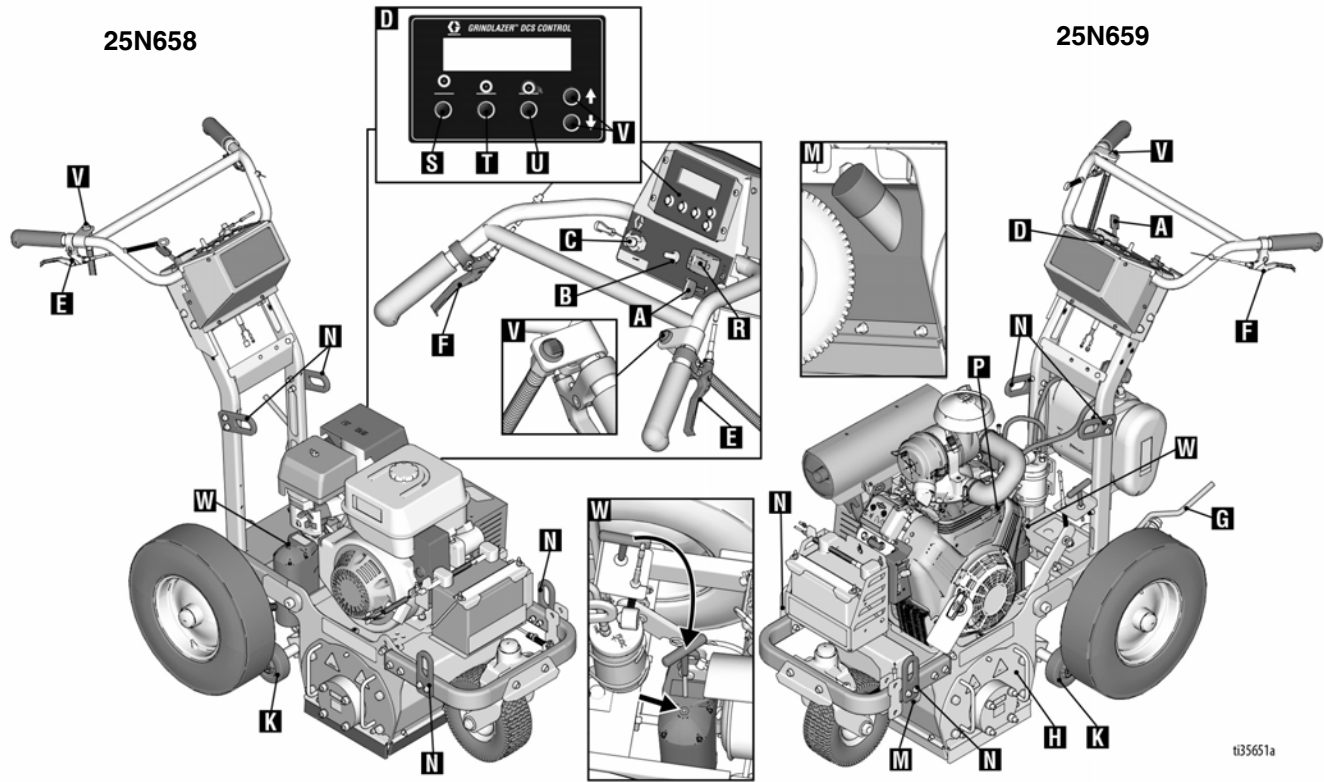

	Component	Description
A	Engine Throttle Lever	Adjusts engine speed.
B	Power Switch	Supplies power to Engine
C	Engine Kill Button	Clamps onto the operator and shuts engine off if cord is disconnected during operation.
D	Drum Adjustment Dial	Sets depth of drum cut.
E	Drum Engage Lever	Handle bars can be pushed down to raise the cutting drum off of surface and locked into UP position. Once drum is locked in UP position, GrindLazer can be moved around without drum touching surface. To lower the drum to the surface, push down on handlebars, engage the Drum Engage Lever and then slowly pull the handlebars up.
F	Front Wheel Lock Lever	Front wheel is usually locked to guide GrindLazer in a straight line. When lever is engaged, front wheel becomes unlocked and is allowed to turn freely.
G	Rear Wheel Parking Brake	Prevents rear wheel from moving.
H	Drum Access Panel	Removable plate that allows access to replace cutting drum.
K	Depth Control Wheels	Levels cutting drum.
M	Vacuum Port	Port to attach vacuum to reduce dust and debris during operation.
N	Lift Points	Reinforced points used for lifting GrindLazer during transportation or repair.
P	Ignition Switch	Electric Start Engine (DC1021 G Model Only)
R	Tachometer/Hour Meter	Displays the RPMs of the engine while running and displays total hours of engine run time.

# Component Identification (DCS Models)



Component	Description
A	Engine Throttle Lever Adjusts engine speed.
B	Power Switch Supplies power to DCS Control and Engine.
C	Engine Kill Button Clamps onto the operator and shuts engine off if cord is disconnected during operation.
D	DCS Control Controls and displays depth of drum cut.
E	Drum Engage Lever Handle bars can be pushed down to raise the cutting drum off of surface and locked into UP position. Once drum is locked in UP position, GrindLazer can be moved around without drum touching surface. To lower the drum to the surface, push down on handlebars, engage the Drum Engage Lever and then slowly pull the handlebars up.
F	Front Wheel Lock Lever Front wheel is usually locked to guide GrindLazer in a straight line. When lever is engaged, front wheel becomes unlocked and is allowed to turn freely.
G	Rear Wheel Parking Brake Prevents rear wheel from moving.
H	Drum Access Panel Removable plate that allows access to replace cutting drum.
K	Depth Control Wheels Levels cutting drum.
M	Vacuum Port Port to attach vacuum to reduce dust and debris during operation.
N	Lift Points Reinforced points used for lifting GrindLazer during transportaton or repair.
P	Ignition Switch Electric Start Engine.
R	Tachometer/Hour Meter Displays the RPMs of the engine while running and displays total hours of engine run time.
S	Home Button Raises drum off the surface to highest position.
T	Zero Button Brings the drum to the surface (reprogrammable).
U	Cut Depth Button Lowers drum to the desired cut depth target (reprogrammable).
V	Up/Down Buttons Raises or Lowers the drum.
W	Manual Height Adjustment Remove screw plug to adjust drum height using 6mm hex key.

# Drum Replacement

			
<p>Avoid touching or handling drum after use until it has completely cooled. To avoid injury from unexpected start up, disconnect spark plug wire and black battery cable (electric start models only) before you service your unit.</p>			

## Removal

1. Remove four bolts and Drum Access Panel (H).

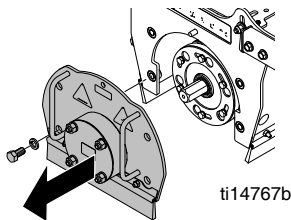

2. Slide drum off of hex shaft.

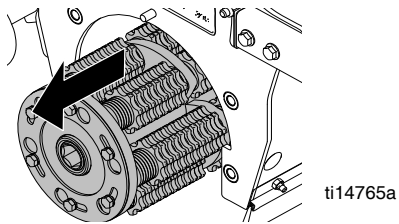

## Installation

**NOTE:** Carbide flail cutter drums do not require specific orientation or direction. Carbide millers and diamond blades are directional. They should be stacked so that the arrows on the millers, PCDs, and blades face the same direction as the rotation of the drum.

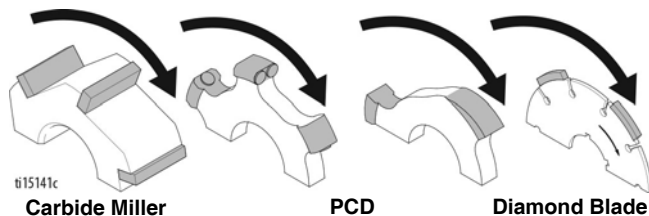

Models **25M992**, **25M993** and **25N658** are designed for “forward cut” grinding (the drum rotates in the same direction that it travels). Models **25M994** and **25N659** are designed for “reverse (up-cut)” grinding (the drum rotates in the opposite direction that it travels).

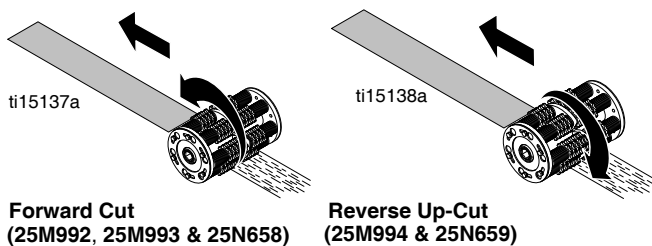

1. Slide replacement drum onto hex shaft.

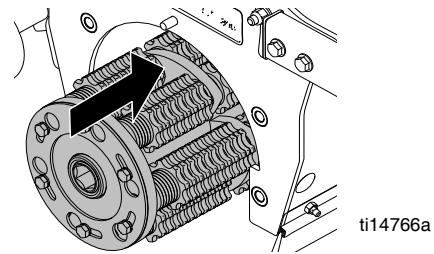

2. **Non-DCS Models:** Lower Drum Adjustment Dial (D) and pull Drum Engage Lever (E) so drum rests on ground and the door pin lines up with the hole.

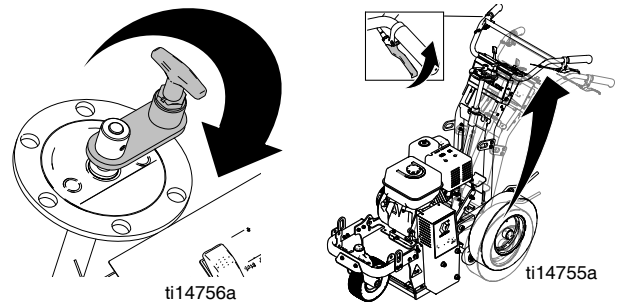

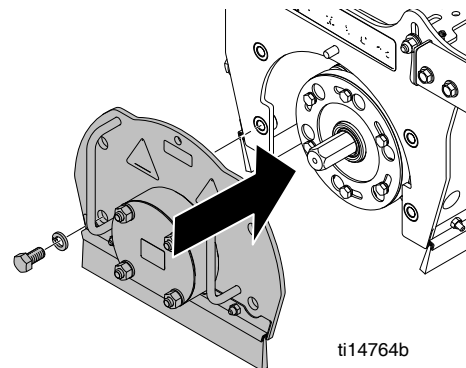

**DCS Models:** Pull the Drum Engage Lever to lower the drum. Turn the Power Switch ON. Use the Up and Down Buttons to raise/lower the drum housing until the drum rests on the ground and the door pin lines up with the hole.

3. Replace Drum Access Panel (H) and tighten four bolts to 27-30 ft-lb (37-41 N•m).



# Cutter Replacement

				
<b>BURN HAZARD</b> Avoid touching or handling drum after use until it has completely cooled.				

Different drum configurations can be used for different applications. Visit [www.graco.com/drumassembly](http://www.graco.com/drumassembly) for instructions on how to assemble various drum configurations.

## Removal (Carbide Flail/Carbide Miller)

1. Remove drum (see **Drum Replacement**, page 7).
2. Remove three bolts on each side of drum. Remove end plates.

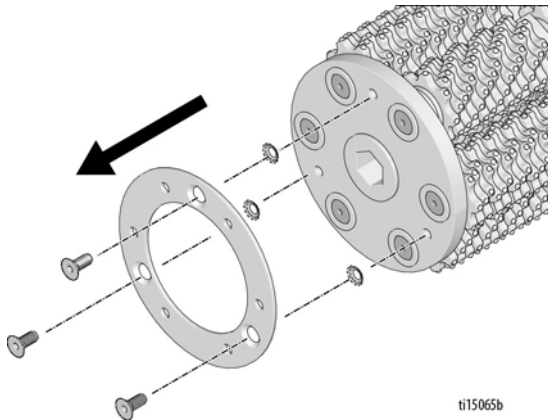

3. Push rod out and remove cutters.

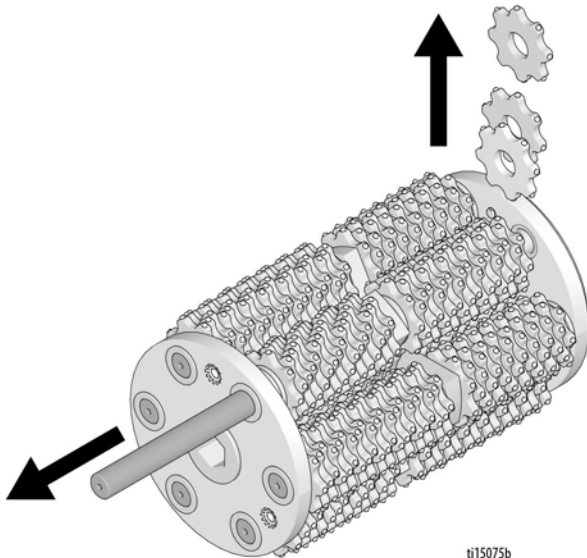

## Installation (Carbide Flail/Carbide Miller)

1. Replace cutters and washers (visit [www.graco.com/drumassembly](http://www.graco.com/drumassembly) for cutter stacking recommendations).

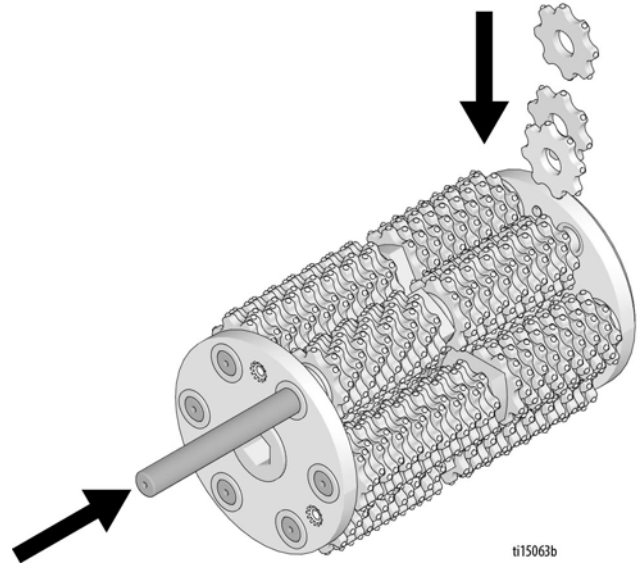

**NOTE:** Cutters must be centered on drum for best performance.

2. Reinstall end plates on each side of drum to cover rods.

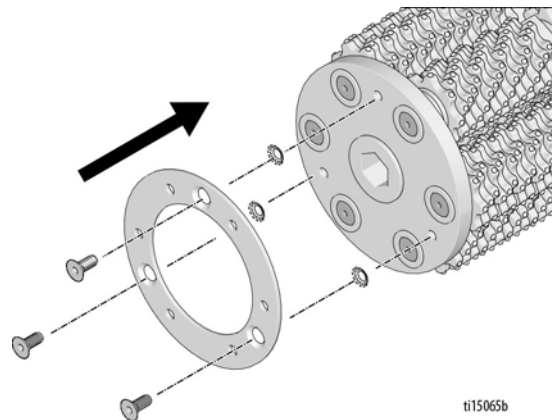

3. Tighten three bolts on each side of drum to 170-180 in-lb (19.2-20.3 N•m).
4. Install drum (see **Drum Replacement**, page 7).

## Removal (Diamond Blades)

1. Remove drum (see **Drum Replacement**, page 7).
2. Place drum in vise.
3. Use spanner wrench to loosen spanner nut (turn clockwise) and remove.

**NOTE:** This nut has a left-hand thread.

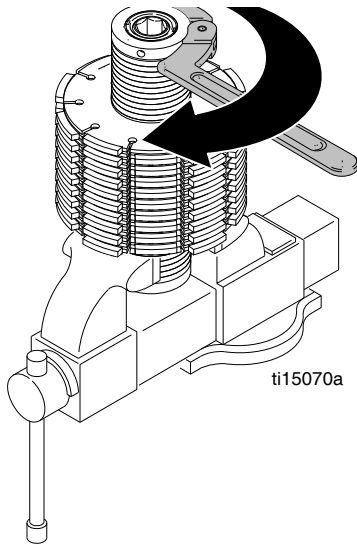

4. Remove all spacers and diamond blades.

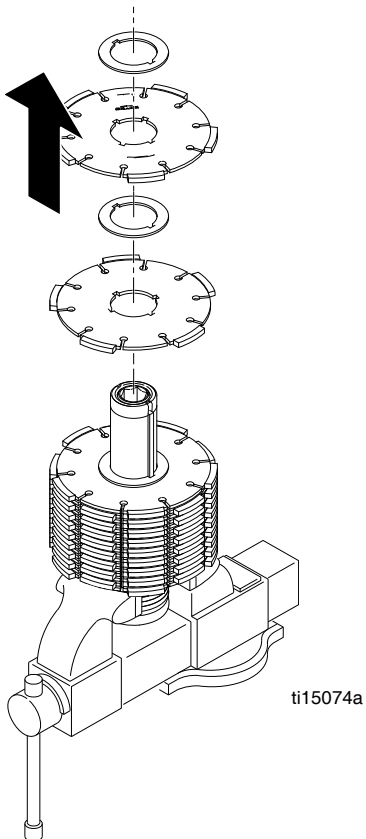

## Installation (Diamond Blades)

1. Replace all spacers and diamond blades in the sequence and orientation shown below (blades should be rotated in alternating segments when stacking).

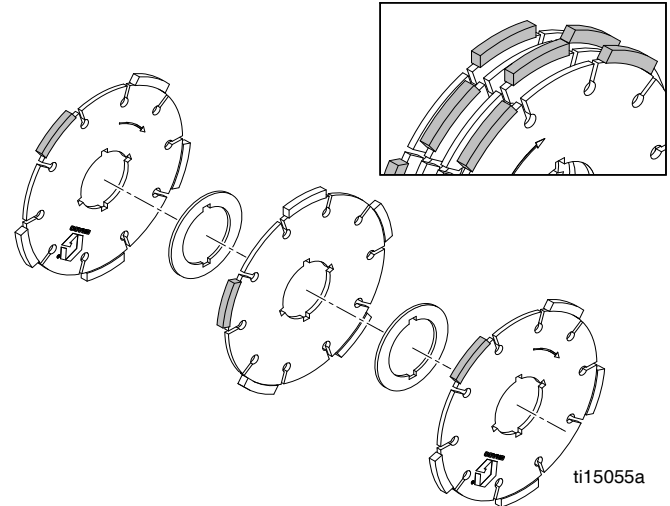

**NOTE:** Blades must be centered on drum for best performance.

2. Clean thread of dust and debris. Apply blue grade/medium strength threadlocker. Use spanner wrench to tighten spanner nut flush with end of the drive shaft (turn counter-clockwise).

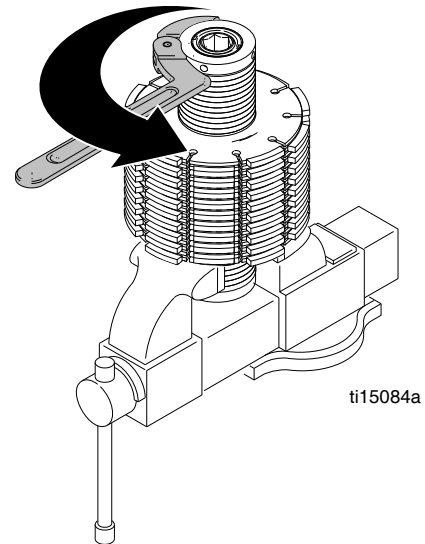

3. Remove drum from vise and install drum (see **Drum Replacement**, page 7).

# Diamond Blades

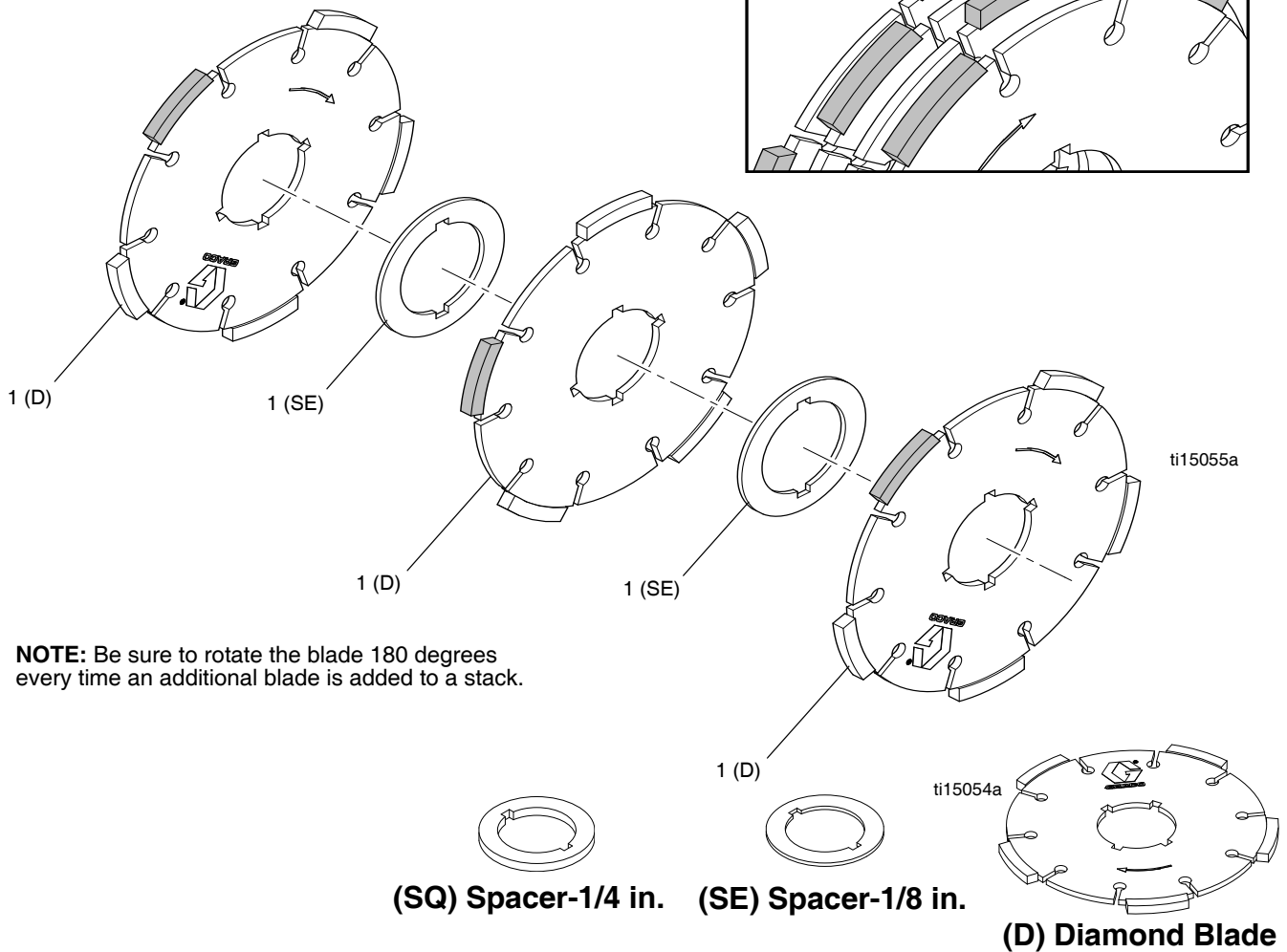
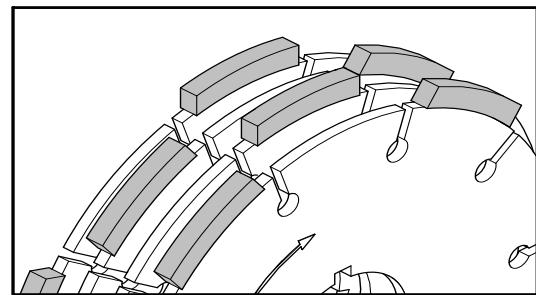
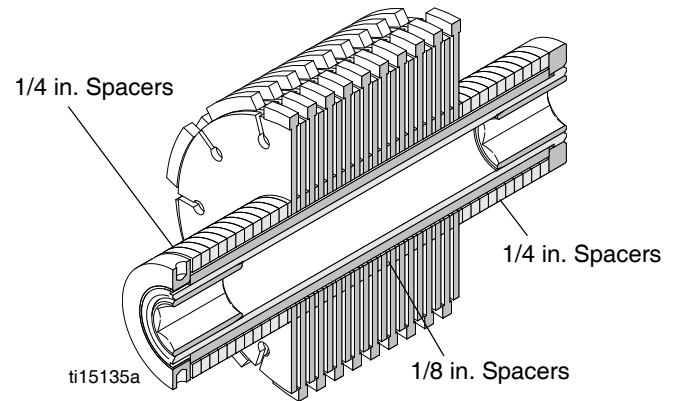

Groove Width	Number of Blades	Number of Steel 1/8 in. Spacers	Number of Aluminum 1/4 in. Spacers
1 in. (2.5 cm)	4	5	36
2 in. (5 cm)	8	9	32
3 in. (7.5 cm)	12	13	28
4 in. (10 cm)	16	17	23
5 in. (12.5 cm)	19	21	21
6 in. (15 cm)	23	24	15
7 in. (17.5 cm)	27	28	11
8 in. (20 cm)	31	32	7
9 in. (23 cm)	35	36	3
10 in. (25 cm)	38	39	2

For best performance, use 1/4 in. spacers on each end of shaft to center diamond blades on drum.



**NOTE:** Be sure to rotate the blade 180 degrees every time an additional blade is added to a stack.

# Belt Replacement

				
<p>To avoid injury from unexpected start up, disconnect spark plug wire and black battery cable (electric start models only) before you service your unit.</p>				

## Removal

1. Remove three nuts and washers. Remove belt shroud.

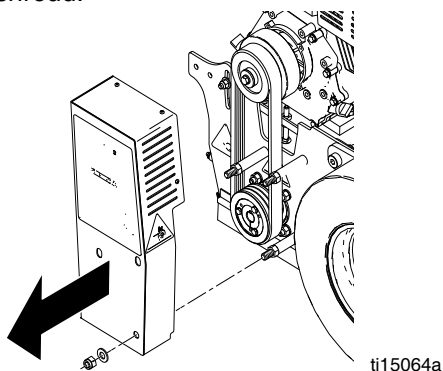

2. Loosen jam nut through two sides of belt.

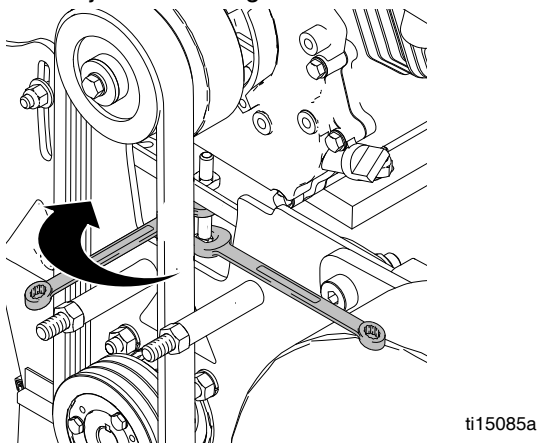

3. Use two wrenches to loosen motor mount bolts on each side of scarifier base.

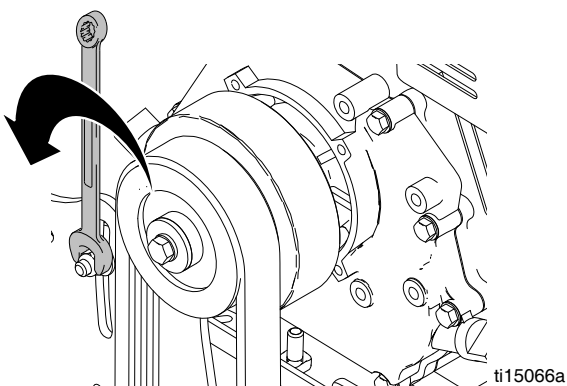

4. Tighten bottom bolt to lower pulley plate.

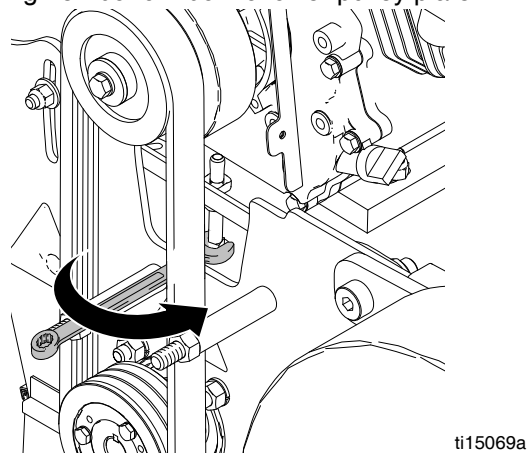

5. Remove used belt.

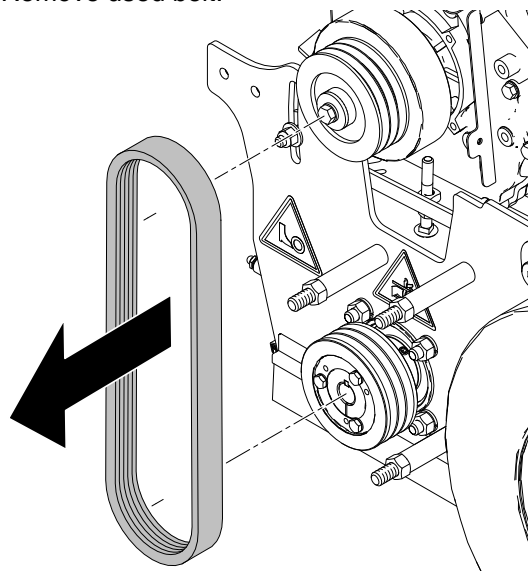

## Installation

1. Install new belt.

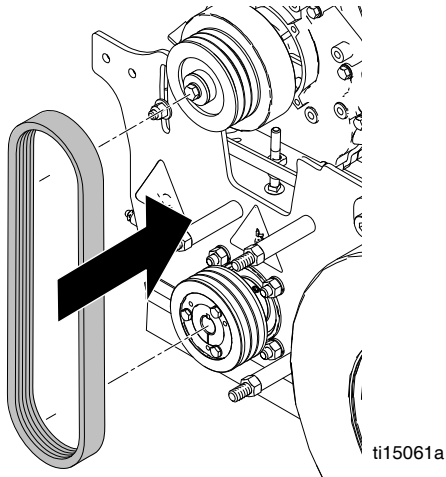

2. Use two wrenches to tighten motor mount adjustment bolts on each side of scarifier base.

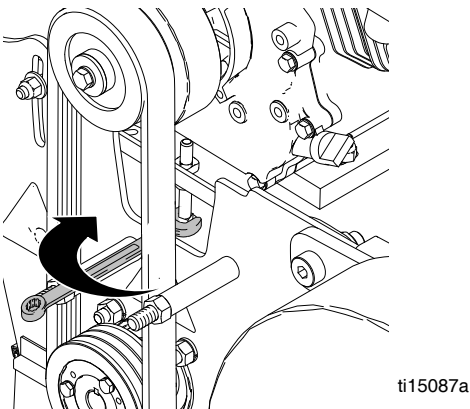

3. Tighten belt adjustment bolt according to recommended tension below.

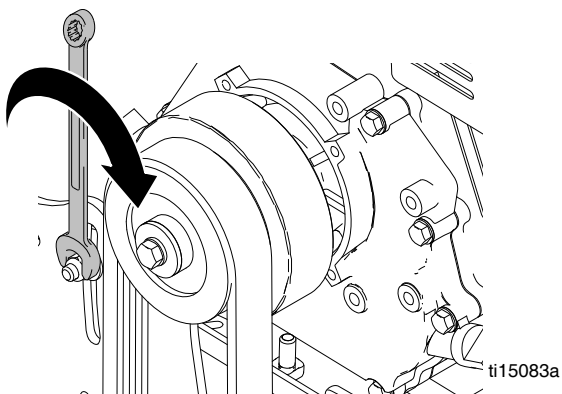

### Belt Tension Recommendations:

		3VX355 Belt	DC89	DC1013	DC1021
New Belt	Tension (Lbf)	145 +/- 5	193 +/- 7	194 +/- 7	194 +/- 7
	Frequency (Hz)	91 +/- 2	105 +/- 2	105 +/- 2	105 +/- 2
Used Belt	Tension (Lbf)	125 +/- 5	167 +/- 7	167 +/- 7	167 +/- 7
	Frequency (Hz)	85 +/- 2	98 +/- 2	98 +/- 2	98 +/- 2

4. Tighten jam nut through two sides of belt.

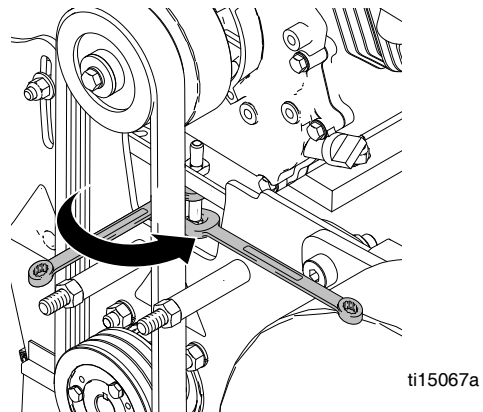

5. Replace belt shroud and tighten three nuts and four screws.

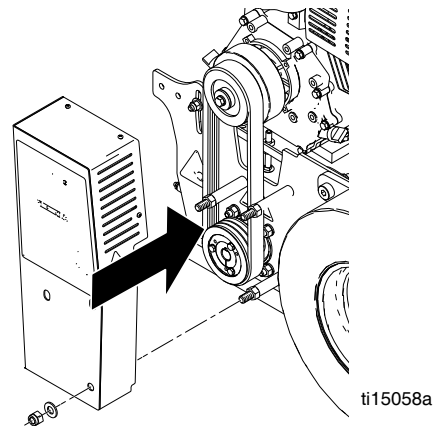

# Clutch Replacement

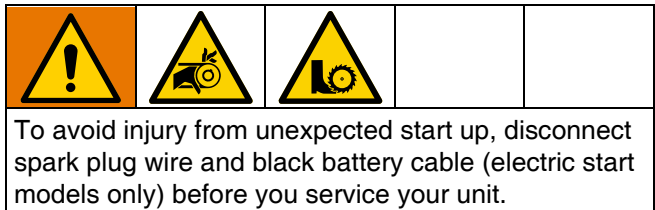

## Removal

1. Remove belt guard and belt (see **Belt Replacement**, page 11).
2. Use impact wrench to remove clutch bolt.

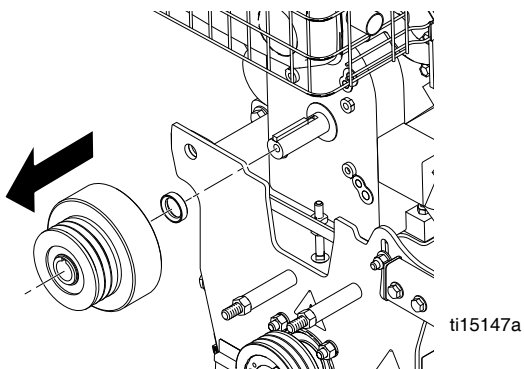

3. Remove used clutch.

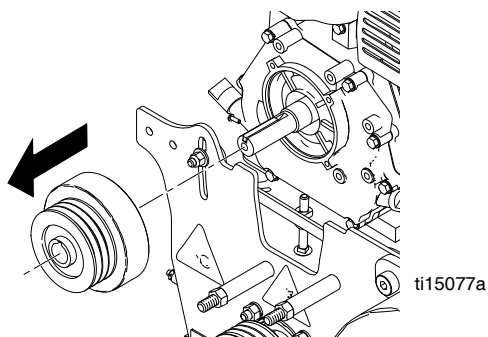

## Installation

1. Install clutch.

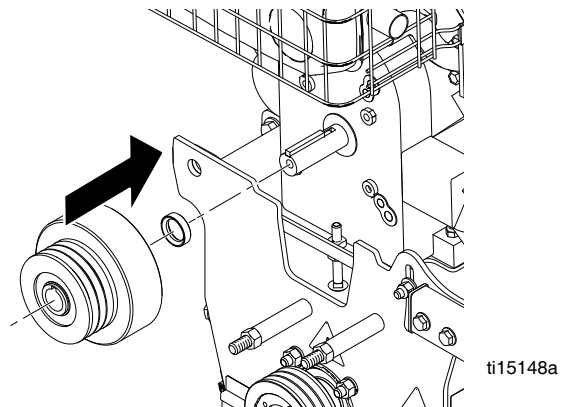

2. Use impact wrench to tighten clutch bolt.

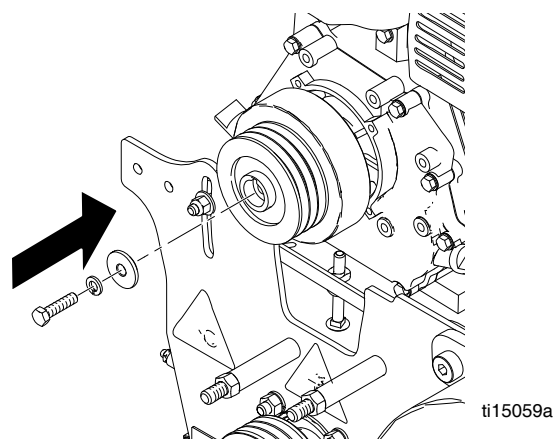

3. Install belt and belt guard (see **Belt Replacement**, page 11).

# Pulley Replacement



To avoid injury from unexpected start up, disconnect spark plug wire and black battery cable (electric start models only) before you service your unit.

## Removal

1. Remove drum (see **Drum Replacement**, page 7).
2. Remove belt guard and belt (see **Belt Replacement**, page 11).
3. Remove the three belt pulley bolts and washers.

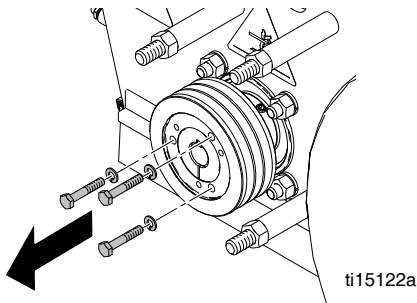

4. Insert the three bolts into the pulley removal holes. Evenly tighten the screws to slowly remove pulley.

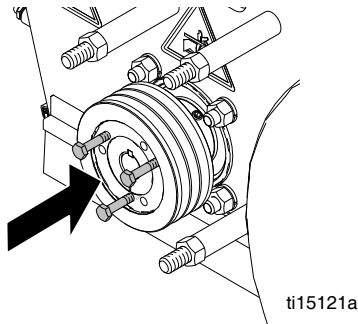

5. Remove pulley.

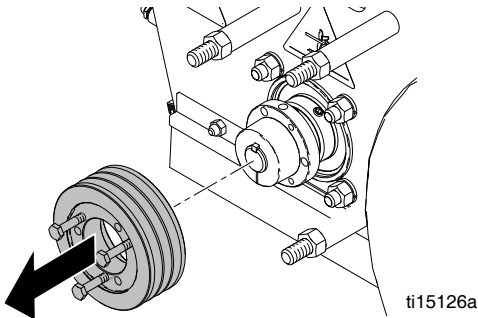

## Installation

6. Install pulley onto hex shaft.

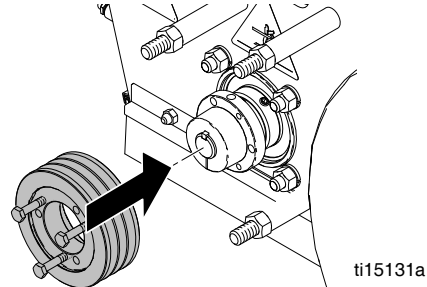

7. Insert three pulley bolts and washers.

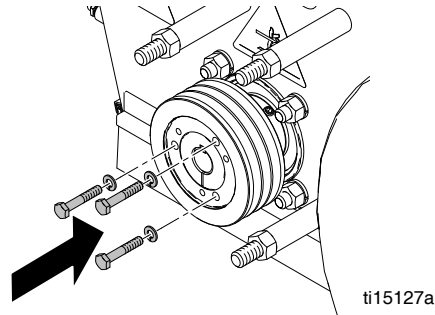

8. Replace belt guard and belt (see **Belt Replacement**, page 11).
9. Replace drum (see **Drum Replacement**, page 7).

# Brush Replacement

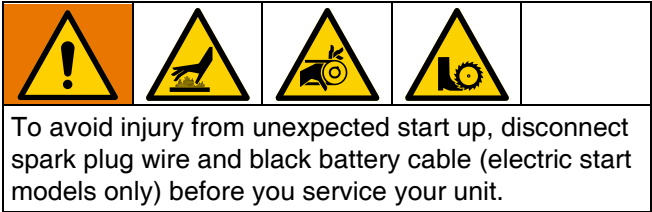

## Removal

1. Remove two mounting bolts.

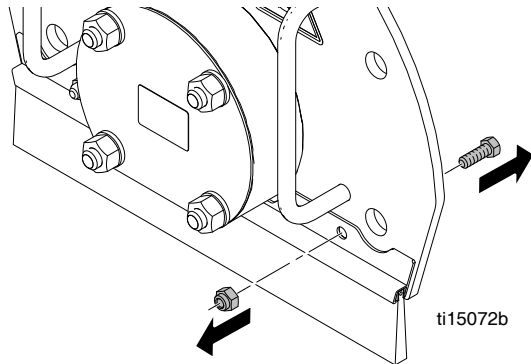

2. Remove used brush.

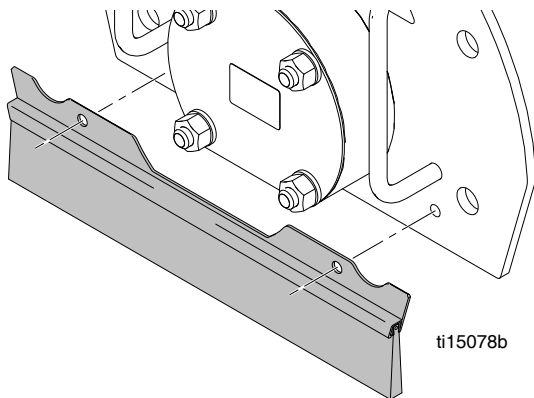

## Installation

1. Install new brush.

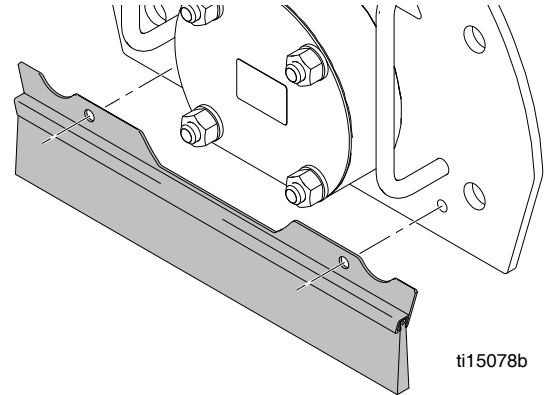

2. Tighten two mounting bolts.

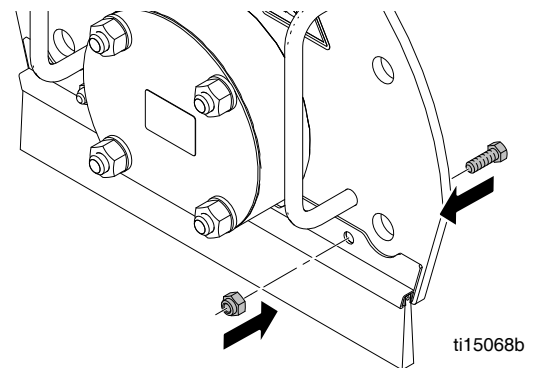

# Drive Bearing Assembly Replacement



To avoid injury from unexpected start up, disconnect spark plug wire and black battery cable (electric start models only) before you service your unit.

## Door Bearing Assembly Removal

1. Remove four nuts holding bearing assembly onto door and remove door.

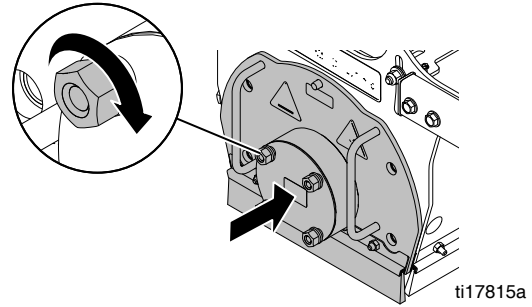
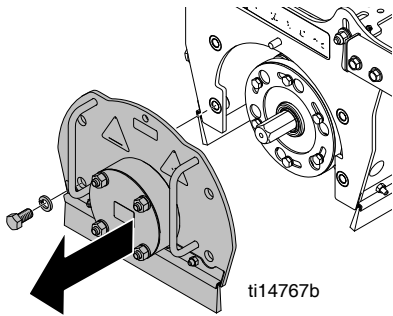

4. Tighten four nuts on bearing assembly to secure it into place.
5. Tighten four bolts to hold door in place.

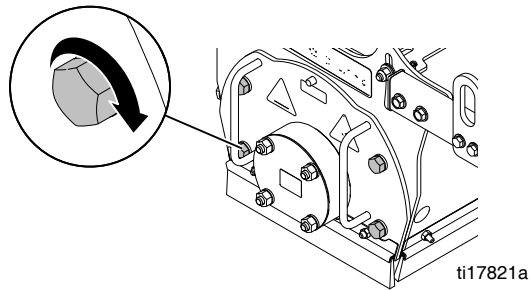

## Door Bearing Assembly Installation

1. Insert new door bearing assembly through hole in door. **NOTE:** Make sure shaft seal is on the inside of the cage.

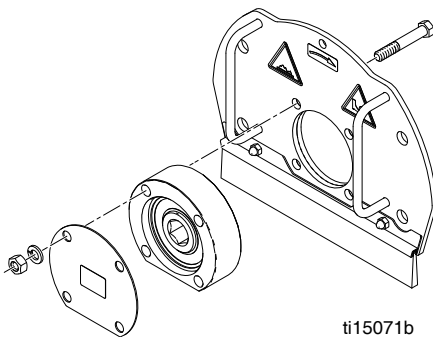

2. Install dust cover onto bearing. Hand-tighten nuts and lock washers to the door. **NOTE:** Do NOT fully tighten bolts at this time.
3. Assemble door onto unit and slide door around until the bearing assembly settles into position for proper alignment.

## Drive Bearing Assembly Removal

1. Remove door from unit and remove any cutting drum on machine.

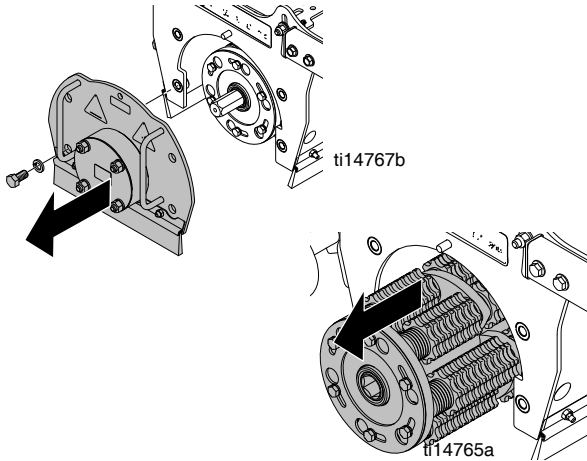

2. Remove belt guard and belt (see page 10).
3. Remove sheave.

- a. Remove the three bolts holding sheave onto bushing.

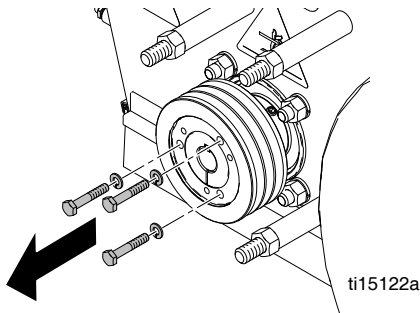

- b. Insert the three bolts into adjacent removal holes and evenly tighten to remove sheave from bushing.

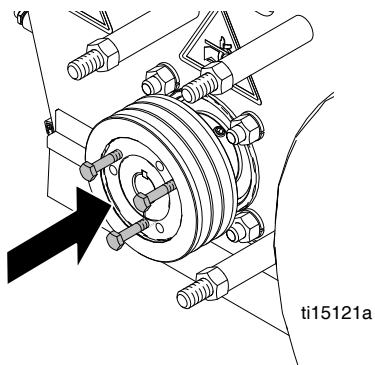

- c. Remove sheave.

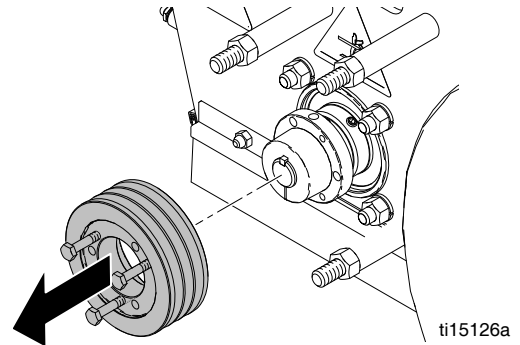

- d. Remove set screw from bushing.

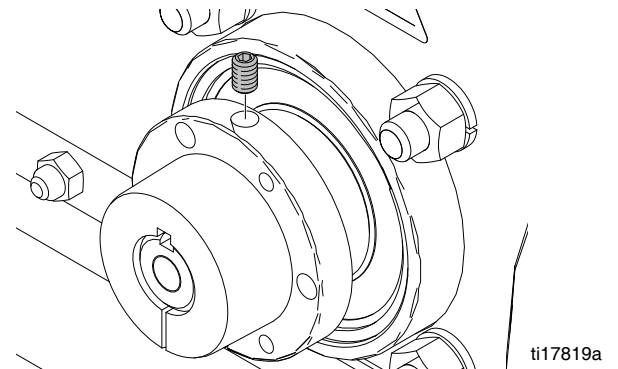

- e. Remove bushing from drive shaft. If bushing is very tight, tap a flat-head screwdriver into slot on bushing to open it up and slide off shaft.

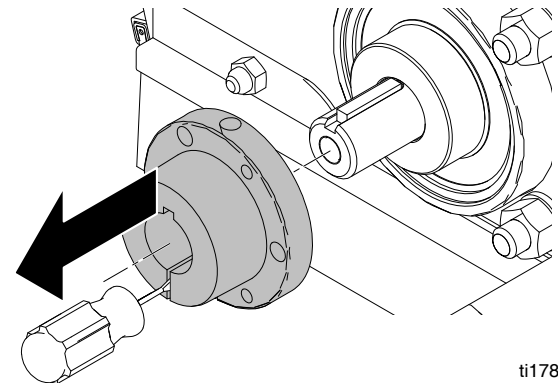

4. Remove all four nuts holding drive side bearing onto cage.

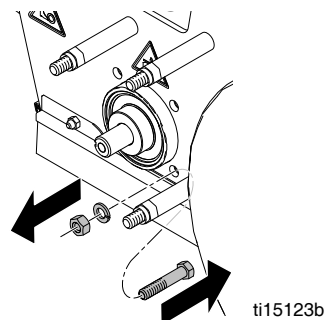

### NOTICE

Do NOT over torque an individual bolt or it will break.

5. Slide shaft assembly out of holes.

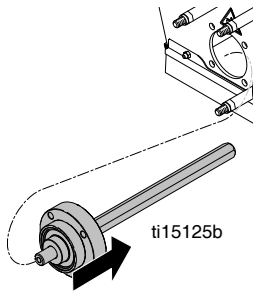

## Drive Bearing Assembly Installation

1. Insert new drive bearing assembly into cage.

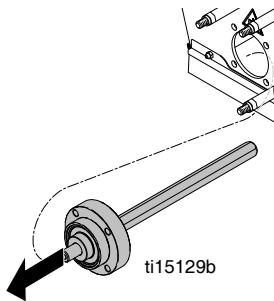

**NOTE:** Be sure to use the shorter bolts for the drive side bearing.

2. Tighten nuts and lock washers to hold bearing assembly in place.

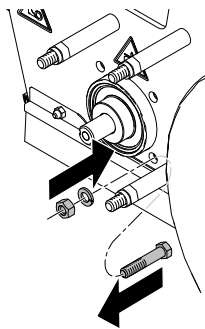

3. Make sure drive shaft key is assembled as shown below.

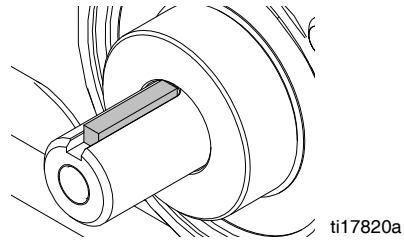

## Sheave Installation

1. Insert bushing onto drive shaft. Make sure key is in place.

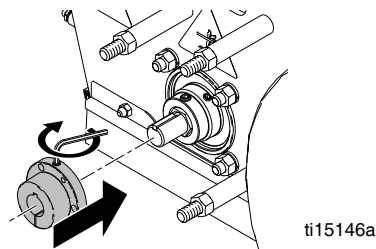

2. Apply thread sealant to set screw and install set screw into bushing.

3. Apply thread sealant to bolt and place lock washer and spacer onto bolt as shown. Thread it into the end of the shaft and tighten. Make sure lock washer is fully compressed.

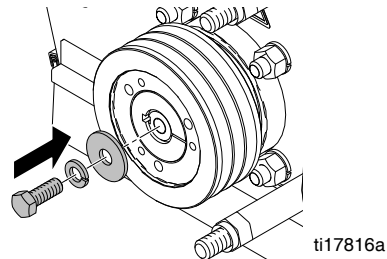

4. Install sheave onto bushing and evenly tighten the three bolts and lock washers to pull the sheave onto the bushing.

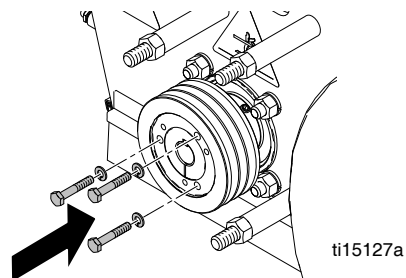

5. Replace belt and belt guard (see page 10).

# Troubleshooting



To avoid injury from unexpected start up, disconnect spark plug wire and black battery cable (electric start models only) before you service your unit.

Problem	Cause	Solution
Engine will not start	Engine switch is OFF.	Turn engine switch ON.
	Engine is out of gas.	Refill gas tank (see engine manual).
	Engine oil level is low.	Try to start engine. Fill oil if necessary (see engine manual).
	Spark plug cable is disconnected or damaged.	Connect spark plug cable or replace spark plug.
	Engine is cold.	Use engine choke.
	Fuel shutoff lever is in OFF position.	Move shutoff lever to ON position.
	Oil is seeping into combustion chamber.	Remove spark plug. Pull starter 3 or 4 times. Clean or replace spark plug. Start engine. Keep sprayer upright to avoid oil seepage.
	<b>DCS Models Only:</b> Power Switch is OFF.	Turn Power Switch ON.
	<b>25M994 Model Only:</b> Emergency shut-off switch is OFF. <b>25M994 &amp; 25N659 Models:</b> Not attached to LineDriver.	Turn emergency shut-off switch ON. Attach LineDriver to unit.
Engine operates, Line-Driver will not move forward or reverse	Low hydraulic oil	Fill with Mobil 1 (15W-50) synthetic oil
	Wheel release is open	Close; hand tighten.
Engine operates, Line-Driver moves slowly in forward or reverse	Low hydraulic oil. Parking brake is set.	Fill with Mobil (15W-050) synthetic oil. Release parking brake.
	Wheel release is open	Close; hand tighten.
Engine shuts off when operator exits LineDriver	Safety switch	Set parking brake
Engine continues to run when operator exits Line-Driver and parking brake is not set	Safety switch	Adjust and set parking brake. Replace safety switch and/or any connecting wires.
Engine misses during turns and forward and reverse changes	Engine oil low	1. Consult engine manual for proper oil. 2. Keep engine oil full to avoid nuisance stalls caused by Oil Alert sensing low oil levels.
Uneven cut	Unbalanced tire pressure	Check tire pressure to make sure both tires are at 60 ft-lb.
Not cutting	Cutters are worn or damaged	Replace cutters.
Engine runs for short time and stops	Fuel flow restriction	See engine manual
Unit vibrates excessively	Cutters not centered on drum.	Reassemble drum with cutters centered on drum.
	Bearings are starting to wear out.	Replace bearings.
	Cutters are worn or damaged.	Replace cutters.
Groove is not even when using diamond blades	Drum rod is not level with drum adjustment wheels.	Adjust drum adjustment wheels so wheels and hex rod are level.
Engine bogs down while grinding	Depth of cut is too deep.	Raise drum.
	Unit is moving too fast.	Slow down.
Not removing material while cutting	Cutters are worn.	Replace cutters.

## DCS Models only

Problem	Cause	Solution
DCS Control not turning on	Blown fuse on DCS Power wire.	Replace fuse on DCS Power wire.
	Power Switch is OFF or damaged.	Turn Power Switch ON. Replace Power Switch if damaged.
	Battery is dead.	Charge Battery.
	DCS Control Board is damaged.	Replace DCS Control Board.
DCS Control runs for short time, then turns off	Engine is not charging the battery. Battery voltage is 14.0-15.0 VDC when engine is full throttle and charging correctly.	Check engine charging coil, voltage rectifier/regulator and fuse inside engine ignition box (25N658 only). Replace or repair if needed.
DCS Control is on, but actuator and/or drum housing does not move	Actuator is disconnected from DCS Control.	Check all connections.
	A DCS Control Switch is pressed or defective.	Ensure all switches are not stuck. Replace switches if defective.
	Actuator rod is stuck.	Manually move the actuator rod using the Manual Height Adjustment feature. Remove screw plug on top of the actuator, then use 6mm hex key to move the rod.
	Actuator or DCS Control Board is damaged.	See flow chart, page 22.
	Battery is low.	Charge battery.
	Drum housing is latched into the "up" position.	Use the Drum Engage Lever to unlatch the drum housing and lower the depth control wheels to the pavement surface.
DCS display does not match Cut Depth.	DCS Control needs to recalibrate its position.	Restart the DCS Control.
	Zero Position is not set to the pavement surface.	Reprogram the Zero Position. See manual 3A5918.
	The wrong GrindLazer model is selected on the DCS Control.	Select the correct model on DCS Control. See manual 3A5918.
DCS Control Buttons work, but display is blank	The display is unplugged or damaged.	Check that the display ribbon cable and red/white wire are connected inside Control Box. Replace if damaged.

## DCS Error Codes

To clear an error code on the DCS Control:

1. Turn DCS Power Switch to OFF.
2. Address/Fix the issue.
3. Turn DCS Power Switch to ON.

Error	Cause	Solution
E04: High Voltage (20VDC or greater, measured across battery posts)	Battery is damaged.	Replace battery.
	Engine voltage rectifier/regulator is damaged.	Replace engine voltage rectifier/regulator.
E05: High Motor Current (15 Amps or greater, measured on blue or brown actuator wire)	Actuator rod is stuck.	Manually move the actuator rod using the Manual Height Adjustment feature.
	Too high of load.	Adjust the drum height while the drum is above the pavement surface. This can be done by latching the drum housing to the rear frame by pushing down on the handlebars.
E08: Low Voltage (7VDC or lower, measured across battery posts)	Battery is low/dead.	Charge battery.
	Engine is not charging the battery.	Check the engine charging coil and voltage rectifier/regulator. Replace or repair if needed.
E09: Hall Sensor Error	Actuator Signal Cable is disconnected from DCS Control or is damaged.	Check all connections. Repair or replace if needed.
	Actuator or DCS Control Board is damaged.	See flow chart, page 22.
E12: High Current (short circuit, 60 amps or greater, measured on red or black wire between battery and DCS Control)	A wire or board component has shorted.	Check all wires for shorts. If all wires are okay, the DCS Control board may be damaged and need to be replaced.
E31: Home Button Error	The Home Button is stuck or shorted.	Check to see if Home Button is stuck. If not stuck, replace the Home Button switch.
E32: Zero Button Error	The Zero Button is stuck or shorted.	Check to see if Zero Button is stuck. If not stuck, replace the Zero Button switch.
E33: Cut Depth Button Error	The Cut Depth Button Error is stuck or shorted.	Check to see if Cut Depth Button is stuck. If not stuck, replace the Cut Depth Button switch.
E34: Up Button Error	The Up Button or Handlebar Rocker Switch is stuck or shorted.	<p>Disconnect Handlebar Rocker Switch from the DCS Control. Clear the error code.</p> <p>If the error code reappears 30 seconds after turning the Power Switch back ON, the problem is the Up Button on the DCS Control. Check to see if the Up Button is stuck. If not stuck, replace the Up Button Switch.</p> <p>If the error code does not reappear 30 seconds after turning the Power Switch back ON, the problem is the Handlebar Rocker Switch. Check to see if the switch is stuck. If not stuck, replace the Handlebar Rocker Switch.</p>
E35: Down Button Error	The Down Button or Handlebar Switch is stuck or shorted.	<p>Disconnect Handlebar Rocker Switch from the DCS Control. Clear the error code.</p> <p>If the error code reappears 30 seconds after turning the Power Switch back ON, the problem is the Down Button on the DCS Control. Check to see if the Down Button is stuck. If not stuck, replace the Down Button Switch.</p> <p>If the error code does not reappear 30 seconds after turning the Power Switch back ON, the problem is the Handlebar Rocker Switch. Check to see if the switch is stuck. If not stuck, replace the Handlebar Rocker Switch.</p>

## DCS Actuator Rod Does Not Move

Use this flow chart if the DCS Actuator Rod does not move or if the DCS displays error code E09 (Hall Sensor Error). Reference **Wiring Diagram**, page 23.

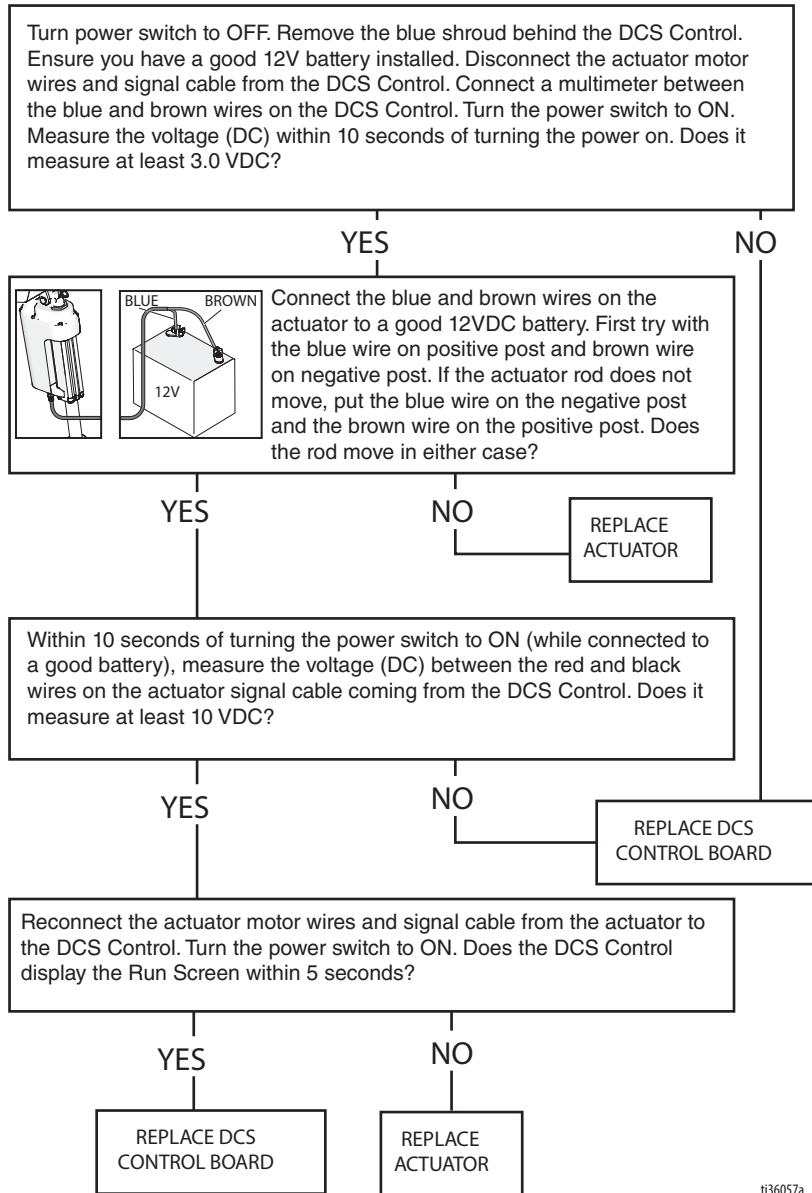

t336057a

# Wiring Diagram

## DCS System

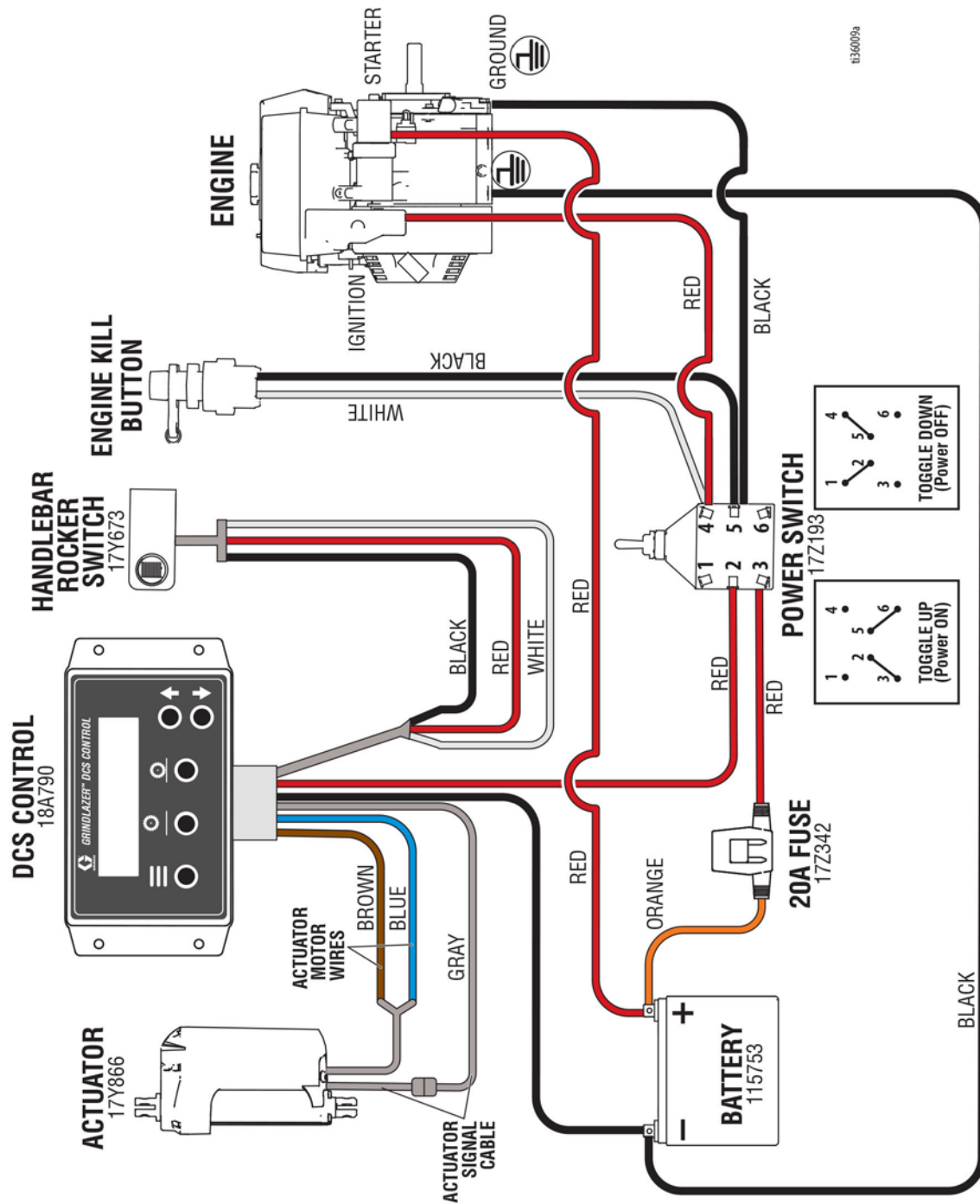

# DCS Control Box

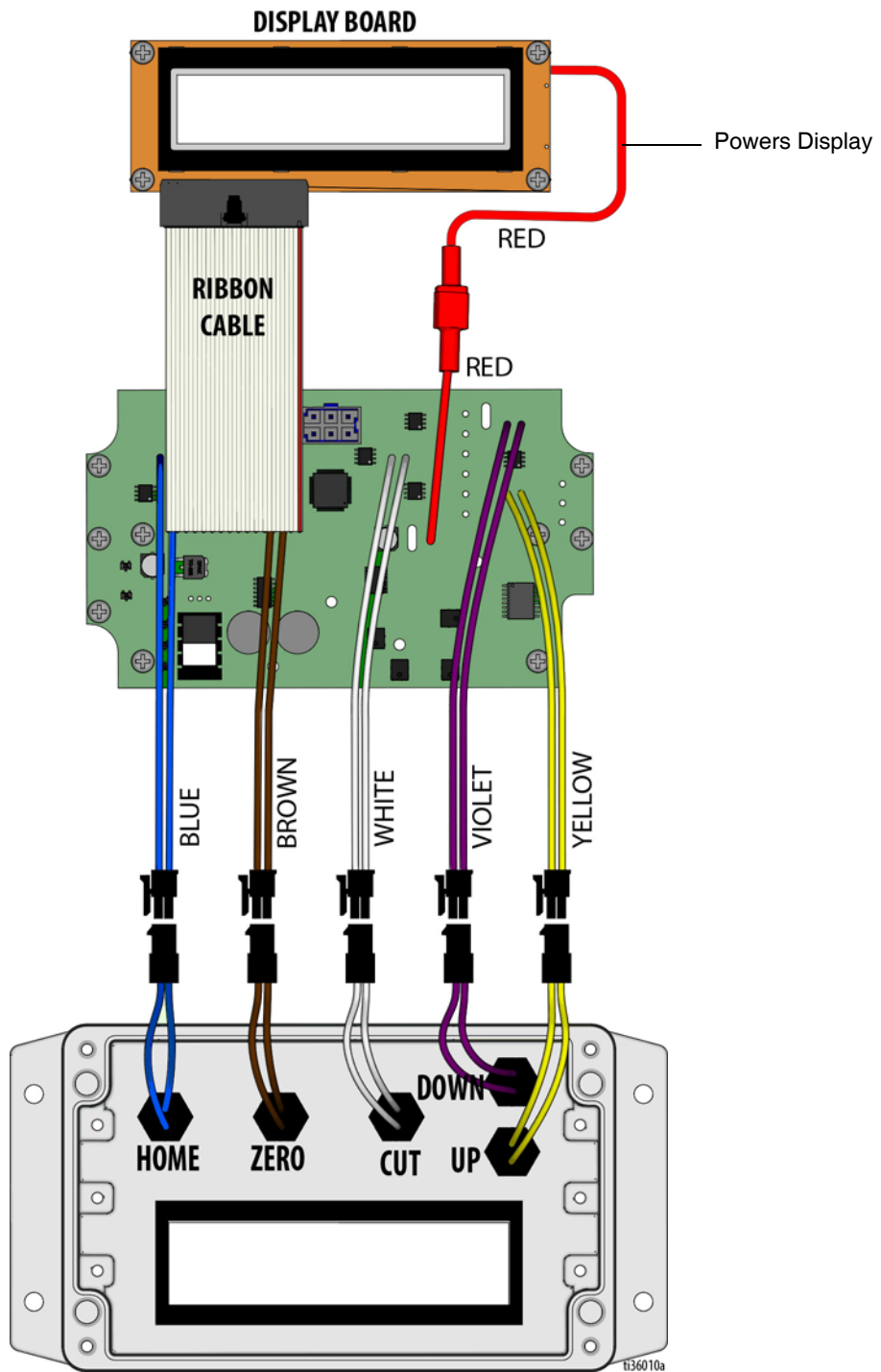

# Technical Data

<b>GrindLazer HP DC89 G (Model 25M992)</b>		
<b>Dimensions</b>		
	<b>Unpackaged</b>	<b>Packaged</b>
Height in./cm:	46 (116.8)	50.5 (128.3)
Width in./cm:	28 (71.1)	37 (94.0)
Length in.cm:	62 (157.5)	73 (185.4)
Weight lb/kg:	300 (136)	400 (181)
<b>Noise (dBa)</b>		
Sound Power per ISO 3744:	107.3	
Sound Pressure measured at 3.1 feet (1m):	91.6	
<b>Vibration (m/sec<sup>2</sup>) per ISO 3744</b>		
Without LineDriver:	7.9	
With LineDriver:	8.3	
<b>Power Rating (HorsePower) per SAE J1349</b>		
8.0 @ 3600 rpm		
Maximum storage time	5 years	
Maximum lifetime	10 years	
Power efficiency factor	200 ground meters per liter fuel	
<b>GrindLazer HP DC1013 (Model 25M993)</b>		
<b>Dimensions</b>		
	<b>Unpackaged</b>	<b>Packaged</b>
Height in./cm:	46 (116.8)	50.5 (128.3)
Width in./cm:	28 (71.1)	37 (94.0)
Length in.cm:	62 (157.5)	73 (185.4)
Weight lb/kg:	310 (141)	410 (186)
<b>Noise (dBa)</b>		
Sound Power per ISO 3744:	109.3	
Sound Pressure measured at 3.1 feet (1m):	93.6	
<b>Vibration (m/sec<sup>2</sup>) per ISO 3744</b>		
Without LineDriver:	7.5	
With LineDriver:	5.9	
<b>Power Rating (HorsePower) per SAE J1349</b>		
11.0 @ 3600 rpm		

<b>GrindLazer HP DC1021 G (Model 25M994)</b>		
<b>Dimensions</b>		
	<b>Unpackaged</b>	<b>Packaged</b>
Height in./cm:	46 (116.8)	50.5 (128.3)
Width in./cm:	28 (71.1)	37 (94.0)
Length in.cm:	62 (157.5)	73 (185.4)
Weight lb/kg:	365 (165)	465 (211)
<b>Noise (dBa)</b>		
Sound Power per ISO 3744:	108.6	
Sound Pressure measured at 3.1 feet (1m):	92.1	
<b>Vibration (m/sec<sup>2</sup>) per ISO 3744</b>		
With LineDriver:	4.9	
<b>Power Rating (HorsePower) per SAE J1349</b>		
21.0 @ 3600 rpm		
<b>GrindLazer HP DC1013 G DCS (Model 25N658)</b>		
<b>Dimensions</b>		
	<b>Unpackaged</b>	<b>Packaged</b>
Height in./cm:	46 (116.8)	50.5 (128.3)
Width in./cm:	28 (71.1)	37 (94.0)
Length in.cm:	62 (157.5)	73 (185.4)
Weight lb/kg:	355 (161)	455 (206)
<b>Noise (dBa)</b>		
Sound Power per ISO 3744:	109.3	
Sound Pressure measured at 3.1 feet (1m):	93.6	
<b>Vibration (m/sec<sup>2</sup>) per ISO 3744</b>		
Without LineDriver:	7.5	
With LineDriver:	5.9	
<b>Power Rating (HorsePower) per SAE J1349</b>		
11.0 @ 3600 rpm		
<b>GrindLazer HP DC1021 G DCS (Model 25N659)</b>		
<b>Dimensions</b>		
	<b>Unpackaged</b>	<b>Packaged</b>
Height in./cm:	46 (116.8)	50.5 (128.3)
Width in./cm:	28 (71.1)	37 (94.0)
Length in.cm:	62 (157.5)	73 (185.4)
Weight lb/kg:	385 (175)	485 (220)
<b>Noise (dBa)</b>		
Sound Power per ISO 3744:	108.6	
Sound Pressure measured at 3.1 feet (1m):	92.1	
<b>Vibration (m/sec<sup>2</sup>) per ISO 3744</b>		
With LineDriver:	4.9	
<b>Power Rating (HorsePower) per SAE J1349</b>		
21.0 @ 3600 rpm		

# Graco Standard Warranty

Graco warrants all equipment referenced in this document which is manufactured by Graco and bearing its name to be free from defects in material and workmanship on the date of sale to the original purchaser for use. With the exception of any special, extended, or limited warranty published by Graco, Graco will, for a period of twelve months from the date of sale, repair or replace any part of the equipment determined by Graco to be defective. This warranty applies only when the equipment is installed, operated and maintained in accordance with Graco's written recommendations.

This warranty does not cover, and Graco shall not be liable for general wear and tear, or any malfunction, damage or wear caused by faulty installation, misapplication, abrasion, corrosion, inadequate or improper maintenance, negligence, accident, tampering, or substitution of non-Graco component parts. Nor shall Graco be liable for malfunction, damage or wear caused by the incompatibility of Graco equipment with structures, accessories, equipment or materials not supplied by Graco, or the improper design, manufacture, installation, operation or maintenance of structures, accessories, equipment or materials not supplied by Graco.

This warranty is conditioned upon the prepaid return of the equipment claimed to be defective to an authorized Graco distributor for verification of the claimed defect. If the claimed defect is verified, Graco will repair or replace free of charge any defective parts. The equipment will be returned to the original purchaser transportation prepaid. If inspection of the equipment does not disclose any defect in material or workmanship, repairs will be made at a reasonable charge, which charges may include the costs of parts, labor, and transportation.

**THIS WARRANTY IS EXCLUSIVE, AND IS IN LIEU OF ANY OTHER WARRANTIES, EXPRESS OR IMPLIED, INCLUDING BUT NOT LIMITED TO WARRANTY OF MERCHANTABILITY OR WARRANTY OF FITNESS FOR A PARTICULAR PURPOSE.**

Graco's sole obligation and buyer's sole remedy for any breach of warranty shall be as set forth above. The buyer agrees that no other remedy (including, but not limited to, incidental or consequential damages for lost profits, lost sales, injury to person or property, or any other incidental or consequential loss) shall be available. Any action for breach of warranty must be brought within two (2) years of the date of sale.

**GRACO MAKES NO WARRANTY, AND DISCLAIMS ALL IMPLIED WARRANTIES OF MERCHANTABILITY AND FITNESS FOR A PARTICULAR PURPOSE, IN CONNECTION WITH ACCESSORIES, EQUIPMENT, MATERIALS OR COMPONENTS SOLD BUT NOT MANUFACTURED BY GRACO.** These items sold, but not manufactured by Graco (such as electric motors, switches, hose, etc.), are subject to the warranty, if any, of their manufacturer. Graco will provide purchaser with reasonable assistance in making any claim for breach of these warranties.

In no event will Graco be liable for indirect, incidental, special or consequential damages resulting from Graco supplying equipment hereunder, or the furnishing, performance, or use of any products or other goods sold hereto, whether due to a breach of contract, breach of warranty, the negligence of Graco, or otherwise.

## **FOR GRACO CANADA CUSTOMERS**

The Parties acknowledge that they have required that the present document, as well as all documents, notices and legal proceedings entered into, given or instituted pursuant hereto or relating directly or indirectly hereto, be drawn up in English. Les parties reconnaissent avoir convenu que la rédaction du présente document sera en Anglais, ainsi que tous documents, avis et procédures judiciaires exécutés, donnés ou intentés, à la suite de ou en rapport, directement ou indirectement, avec les procédures concernées.

# Graco Information

TO PLACE AN ORDER, find us at [rae-prostores.com](http://rae-prostores.com) or call us [1-877-275-7550](tel:1-877-275-7550)



*All written and visual data contained in this document reflects the latest product information available at the time of publication.  
Graco reserves the right to make changes at any time without notice.*

Original instructions. This manual contains English. MM 3A5919

**Graco Headquarters:** Minneapolis

**International Offices:** Belgium, China, Japan, Korea

**GRACO INC. AND SUBSIDIARIES • P.O. BOX 1441 • MINNEAPOLIS MN 55440-1441 • USA**  
**Copyright 2018, Graco Inc. All Graco manufacturing locations are registered to ISO 9001.**

www.graco.com  
Revision C, February 2020