

GrindLazer™

3A5918C

EN

For removal of materials from flat horizontal concrete and asphalt surfaces. For professional use only.

Model 25M992 - Forward Cut

GrindLazer HP DC89 G (270 cc / 9 hp)

Model 25M993 - Forward Cut

GrindLazer HP DC1013 G (390 cc / 13 hp)

Model 25M994 - Reverse Up-Cut (Must be used with LineDriver™)

GrindLazer HP DC1021 G (627 cc / 21 hp Electric Start)

Model 25N658 - Forward Cut

GrindLazer HP DC1013 G DCS (390 cc / 13 hp Electric Start)

Model 25N659 - Reverse Up-Cut (Must be used with LineDriver™)

GrindLazer HP DC1021 G DCS (627 cc / 21 hp Electric Start)

Related Manuals:

Repair - [3A5919](#)

Parts - [3A5929](#)

LineDriver Operation - [312540](#)

LineDriver ES Operation, Repair, Parts - [3A6623](#)



IMPORTANT SAFETY INSTRUCTIONS

Read all warnings and instructions in this manual and in related manuals before using the equipment. Be familiar with the controls and the proper usage of the equipment. Save all instructions.

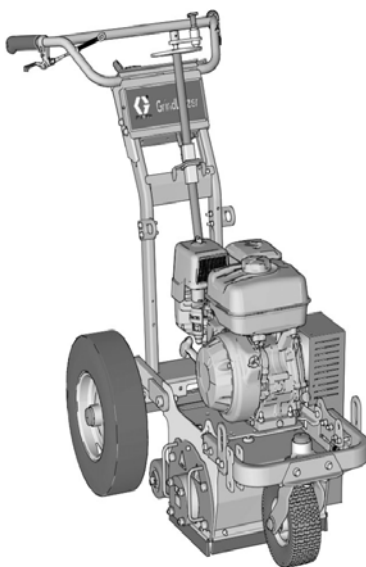

25M992 / 25M993

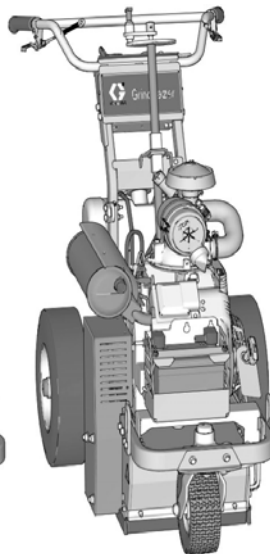

25M994

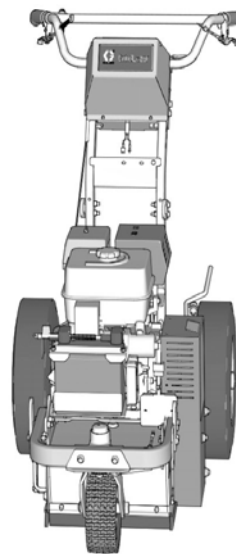

25N658

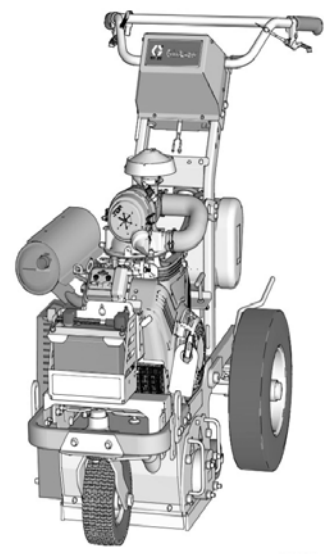

25N659

t135649a

(Drums, cutters, and LineDriver™ sold separately)











PROVEN QUALITY. LEADING TECHNOLOGY.





Contents

Warnings	3	Operation	14
Battery Disposal	4	Start-Up	14
Component Identification	5	Starting the Engine	14
Component Identification (DCS Models)	6	Cutting Material	16
Setup	7	Cutting Drum Assemblies	17
Handle Bar Adjustment	7	Stop Cutting Material	18
Drum Installation/Replacement	7	Clean Up	18
Depth Control Wheels	8	DCS Instructions	19
How to Level the Drum	8	Maintenance	21
Dust Control	9	Caster Wheel Maintenance	21
DCS Control (DCS Models only)	10	DCS Control Translations	22
		Technical Data	24
		Graco Standard Warranty	26

Warnings

The following warnings are for the setup, use, grounding, maintenance, and repair of this equipment. The exclamation point symbol alerts you to a general warning and the hazard symbols refer to procedure-specific risks. When these symbols appear in the body of this manual or on warning labels, refer back to these Warnings. Product-specific hazard symbols and warnings not covered in this section may appear throughout the body of this manual where applicable.

 <h2 style="margin: 0;">WARNING</h2>	
 	<p>DUST AND DEBRIS HAZARD</p> <p>Grinding concrete and other surfaces with this equipment can create dust that contains hazardous substances. Grinding can also create flying debris.</p> <p>To reduce the risk of serious injury:</p> <ul style="list-style-type: none"> • Control the dust to meet all applicable workplace regulations. • Wear protective eye wear and a properly fit-tested and government approved respirator suitable for the dust conditions. • Use equipment only in a well-ventilated area. • Grinding equipment must be used only by trained personnel who understand the applicable workplace regulations.
 	<p>ENTANGLEMENT AND ROTATING PARTS HAZARD</p> <p>Rotating parts can cut or amputate fingers and other body parts.</p> <ul style="list-style-type: none"> • Keep clear of rotating parts. • Do not operate equipment with protective guards or covers removed. • Do not wear loose clothing, jewelry or long hair while operating equipment. • Before checking, moving, or servicing equipment, disable power supply.
	<p>BURN HAZARD</p> <p>Cutters and engine can become very hot during operation. To avoid severe burns, do not touch hot equipment. Wait until equipment has cooled completely.</p>
	<p>EQUIPMENT MISUSE HAZARD</p> <p>Misuse can cause death or serious injury.</p> <ul style="list-style-type: none"> • Do not operate the unit when fatigued or under the influence of drugs or alcohol. • Do not leave the work area while equipment is energized. Turn off all equipment when equipment is not in use. • Check equipment daily. Repair or replace worn or damaged parts immediately with genuine manufacturer's replacement parts only. • Do not alter or modify equipment. • Use equipment only for its intended purpose. Call your distributor for information. • Keep children and animals away from work area. • Comply with all applicable safety regulations. • Maintain a safe operating distance from other people in the work area. • Avoid any pipes, columns, openings, or any other objects protruding from work surface.
 	<p>PERSONAL PROTECTIVE EQUIPMENT</p> <p>You must wear appropriate protective equipment when operating, servicing, or when in the operating area of the equipment to help protect you from serious injury, including eye injury, inhalation of dust or chemicals, burns, and hearing loss. This equipment includes but is not limited to:</p> <ul style="list-style-type: none"> • Protective eye wear. • Protective shoes. • Gloves. • Hearing protection. • Properly fit-tested and government approved respirator suitable for the dust conditions.

 <h1 style="margin: 0;">WARNING</h1>	
	<p>FIRE AND EXPLOSION HAZARD</p> <p>Flammable fumes, such as solvent and paint fumes, in work area can ignite or explode. To help prevent fire and explosion:</p> <ul style="list-style-type: none"> • Use equipment only in well ventilated area. • Do not fill fuel tank while engine is running or hot; shut off engine and let it cool. Fuel is flammable and can ignite or explode if spilled on hot surface. • Keep work area free of debris, including solvent, rags and gasoline. • Keep a fire extinguisher in work area.
	<p>CARBON MONOXIDE HAZARD</p> <p>Exhaust contains poisonous carbon monoxide, which is colorless and odorless. Breathing carbon monoxide can cause death.</p> <ul style="list-style-type: none"> • Do not operate in an enclosed area.
	<p>BATTERY HAZARD</p> <p>The battery may leak, explode, cause burns, or cause an explosion if mishandled. Contents of an open battery can cause severe irritation and/or chemical burns. If on skin, wash with soap and water. If in eyes, flush with water for at least 15 minutes and get immediate medical attention.</p> <ul style="list-style-type: none"> • Only use the battery type specified for use with the equipment. See Technical Data. • Replace battery only in well-ventilated area and away from flammable or combustible materials, including paints and solvents. • Do not dispose of battery in fire or heat above 50°C (122°F). The battery is capable of exploding. • Do not throw into fire. • Do not expose battery to water or rain. • Do not disassemble, crush, or penetrate the battery. • Do not use or charge a battery that is cracked or damaged. • Follow local ordinances and/or regulations for disposal.
	<p>CALIFORNIA PROPOSITION 65</p> <p>The engine exhaust from this product contains a chemical known to the State of California to cause cancer, birth defects or other reproductive harm.</p> <p>This product contains a chemical known to the State of California to cause cancer, birth defects or other reproductive harm. Wash hands after handling.</p>

Battery Disposal

Do not place batteries in the trash. Recycle batteries according to local regulations. In the USA and Canada call 1-800-822-8837 to find recycling location or go to www.call2recycle.org.

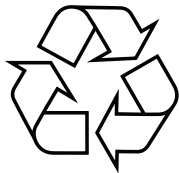

Component Identification

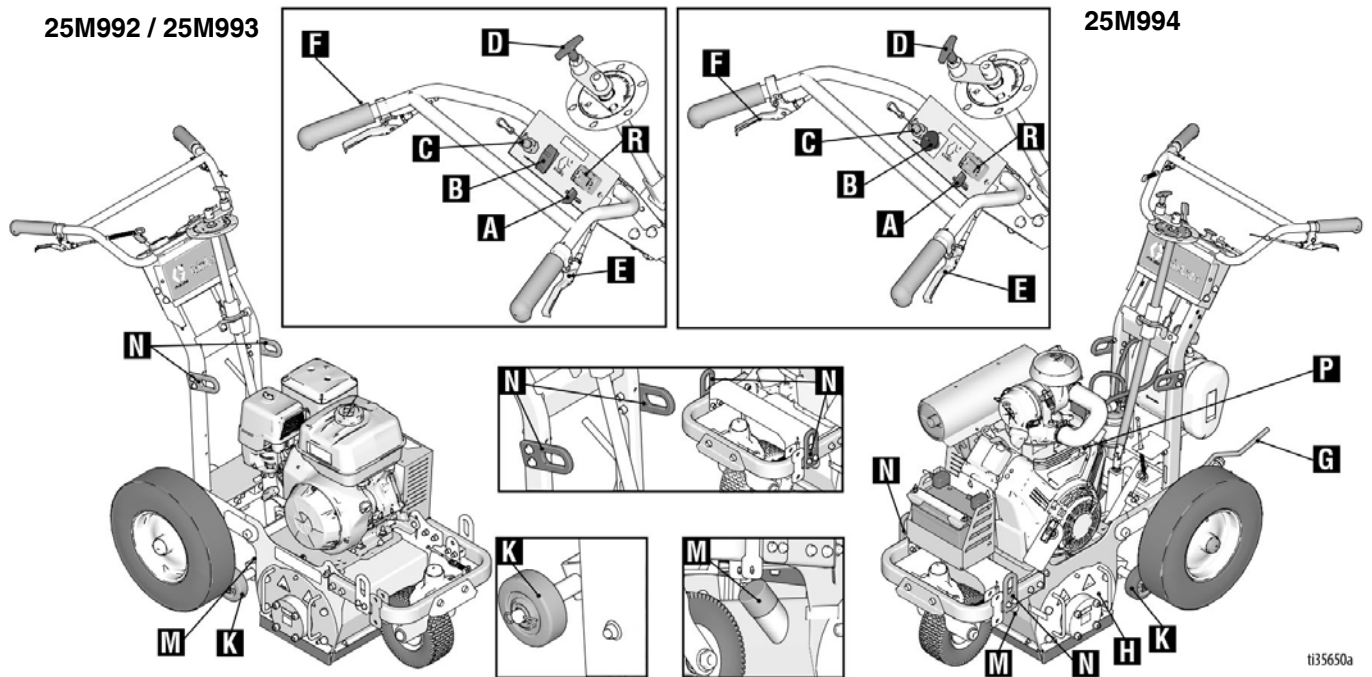

1135650a

	Component	Description
A	Engine Throttle Lever	Adjusts engine speed.
B	Power Switch	Supplies power to Engine
C	Engine Kill Button	Clamps onto the operator and shuts engine off if cord is disconnected during operation.
D	Drum Adjustment Dial	Sets depth of drum cut.
E	Drum Engage Lever	Handle bars can be pushed down to raise the cutting drum off of surface and locked into UP position. Once drum is locked in UP position, GrindLazer can be moved around without drum touching surface. To lower the drum to the surface, push down on handlebars, engage the Drum Engage Lever and then slowly pull the handlebars up.
F	Front Wheel Lock Lever	Front wheel is usually locked to guide GrindLazer in a straight line. When lever is engaged, front wheel becomes unlocked and is allowed to turn freely.
G	Rear Wheel Parking Brake	Prevents rear wheel from moving.
H	Drum Access Panel	Removable plate that allows access to replace cutting drum.
K	Depth Control Wheels	Levels cutting drum.
M	Vacuum Port	Port to attach vacuum to reduce dust and debris during operation.
N	Lift Points	Reinforced points used for lifting GrindLazer during transportaton or repair.
P	Ignition Switch	Electric Start Engine (DC1021 G Model Only)
R	Tachometer/Hour Meter	Displays the RPMs of the engine while running and displays total hours of engine run time.

Component Identification (DCS Models)

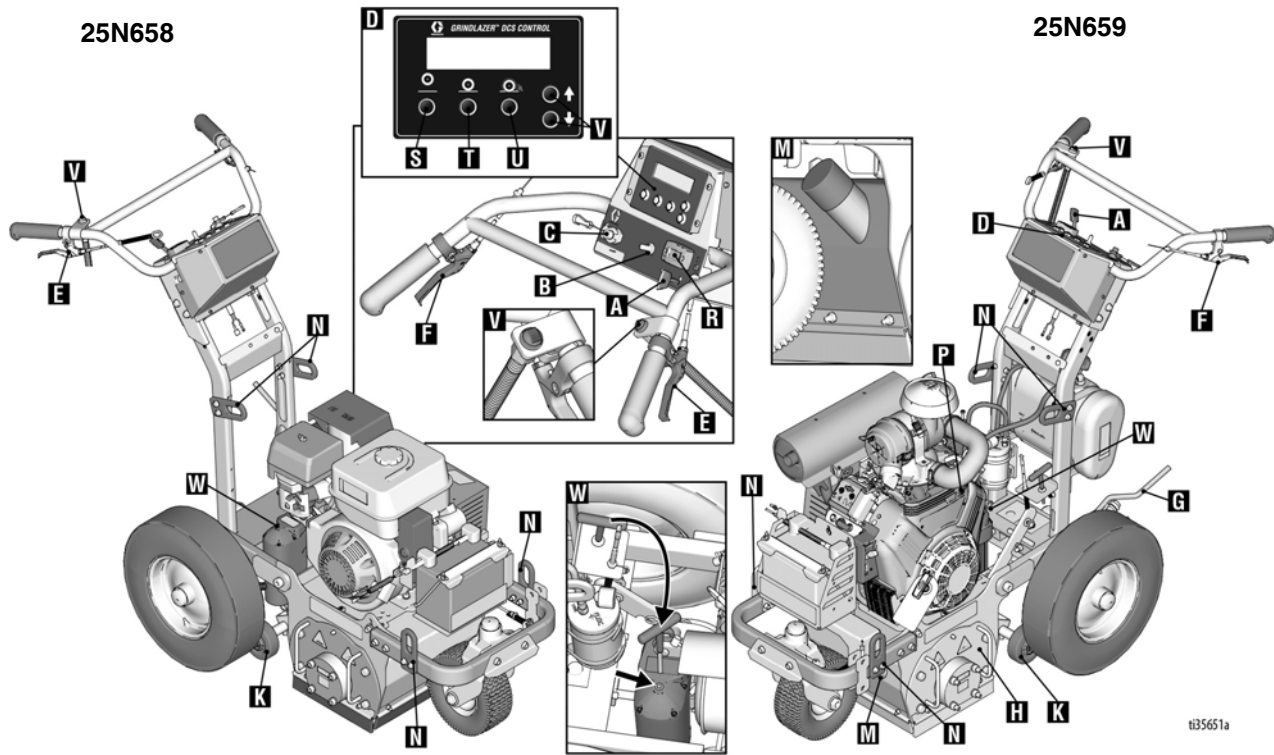

	Component	Description
A	Engine Throttle Lever	Adjusts engine speed.
B	Power Switch	Supplies power to DCS Control and Engine.
C	Engine Kill Button	Clamps onto the operator and shuts engine off if cord is disconnected during operation.
D	DCS Control	Controls and displays depth of drum cut.
E	Drum Engage Lever	Handle bars can be pushed down to raise the cutting drum off of surface and locked into UP position. Once drum is locked in UP position, GrindLazer can be moved around without drum touching surface. To lower the drum to the surface, push down on handlebars, engage the Drum Engage Lever and then slowly pull the handlebars up.
F	Front Wheel Lock Lever	Front wheel is usually locked to guide GrindLazer in a straight line. When lever is engaged, front wheel becomes unlocked and is allowed to turn freely.
G	Rear Wheel Parking Brake	Prevents rear wheel from moving.
H	Drum Access Panel	Removable plate that allows access to replace cutting drum.
K	Depth Control Wheels	Levels cutting drum.
M	Vacuum Port	Port to attach vacuum to reduce dust and debris during operation.
N	Lift Points	Reinforced points used for lifting GrindLazer during transportaton or repair.
P	Ignition Switch	Electric Start Engine.
R	Tachometer/Hour Meter	Displays the RPMs of the engine while running and displays total hours of engine run time.
S	Home Button	Raises drum off the surface to highest position.
T	Zero Button	Brings the drum to the surface (reprogrammable).
U	Cut Depth Button	Lowers drum to the desired cut depth target (reprogrammable).
V	Up/Down Buttons	Raises or Lowers the drum.
W	Manual Height Adjustment	Remove screw plug to adjust drum height using 6mm hex key.

Setup

Models **25M992**, **25M993** and **25N658** are designed to be operated by a single operator positioned at the back of the unit, or in conjunction with LineDriver. Models **25M994** and **25N659** can ONLY be operated with a LineDriver.

Handle Bar Adjustment

To adjust handle bar: remove four screws (S), slide handle bar to desired height, and replace screws and tighten.

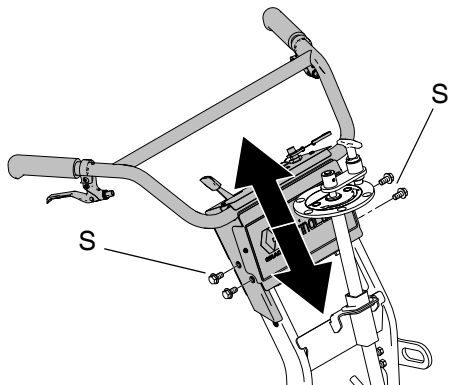

Drum Installation/Replacement

Installation

NOTE: Carbide flail cutter drums do not require specific orientation or direction. Carbide millers and diamond blades are directional. They should be stacked so that the arrows on the millers, PCDs, and blades face the same direction as the rotation of the drum.

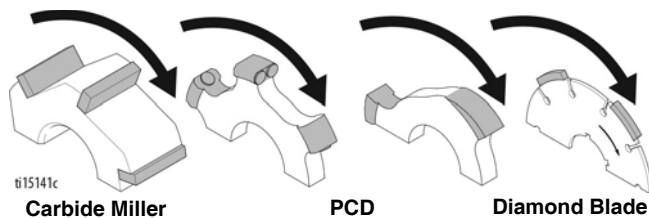

Models **25M992**, **25M993** and **25N658** are designed for “forward cut” grinding (the drum rotates in the same direction that it travels). Models **25M994** and **25N659** are designed for “reverse (up-cut)” grinding (the drum rotates in the opposite direction that it travels).

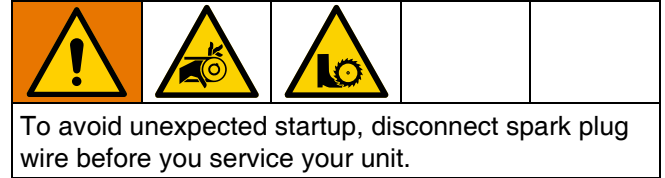
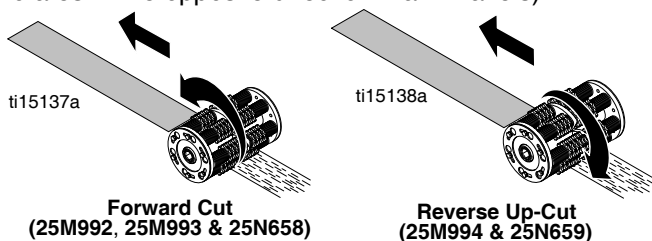

1. Slide replacement Drum onto hex shaft.

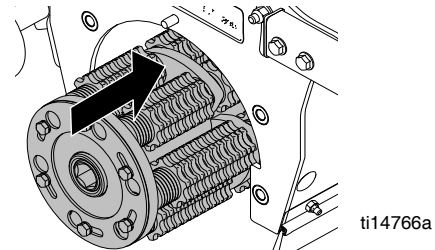

2. Replace Drum Access Panel (H).

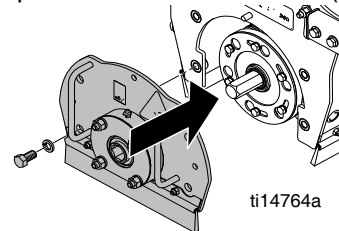

3. **Non-DCS Models:** Lower Drum Adjustment Dial (D) and pull Drum Engage Lever (E) so drum rests on ground and the door pin lines up with the hole.

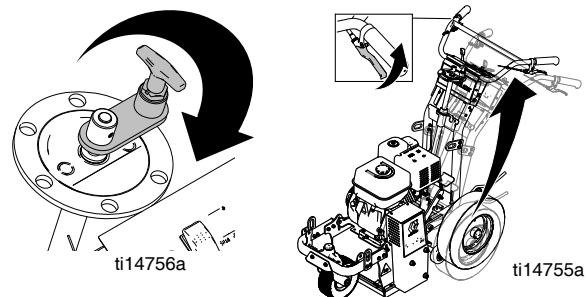

DCS Models: Pull the Drum Engage Lever (E) to lower the drum. Turn the Power Switch ON (B). Use the Up/Down Buttons (V) to raise/lower the drum housing until the drum rests on the ground and the door pin lines up with the hole.

Setup

- Once the proper drum height is achieved, slide the Drum Access Panel onto the hex shaft and door pin.

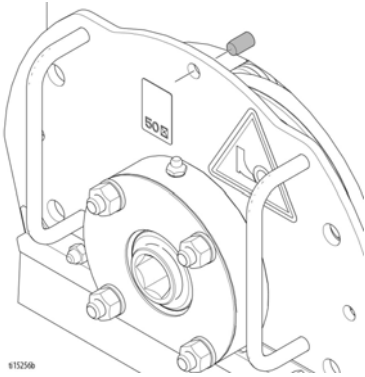

- Tighten four bolts on Drum Access Panel (H).

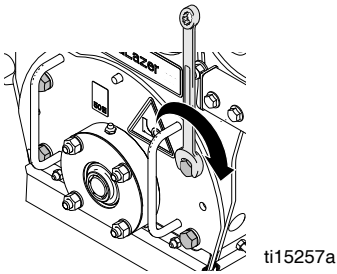

- Non-DCS Models:** Turn Drum Adjustment Dial (D) to maximum height.
DCS Models: Press the Home Button (S) on the DCS Control (D).

Removal

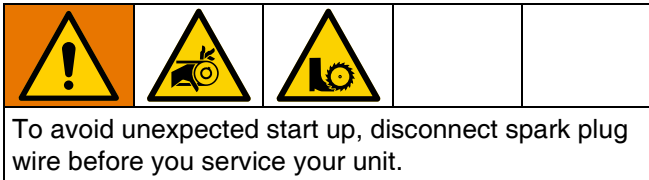

- Remove four bolts and Drum Access Panel (H).

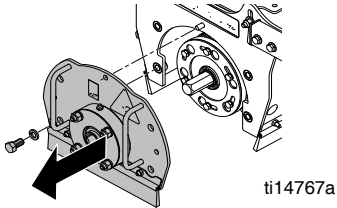

- Slide drum off of hex shaft.

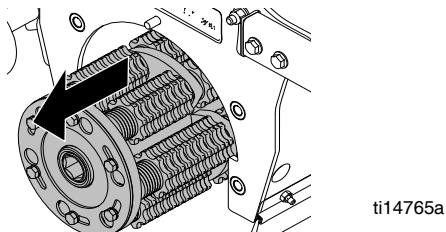

Depth Control Wheels

Using Depth Control Wheels as a 5 in. or 10 in. Wide Cutting Guide

To make a **5 in. cut**, install two spacers (S) on **outside** of Depth Control Wheels (K).

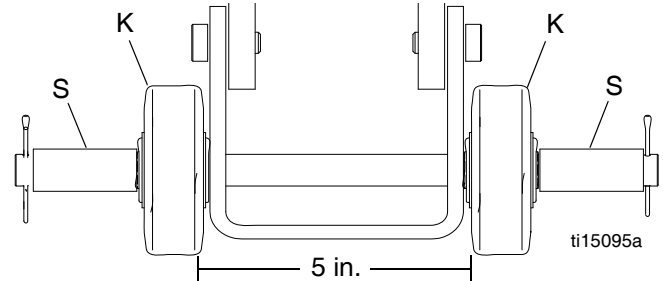

To make a **10 in. cut**, install two spacers (S) on **inside** of Depth Control Wheels (K).

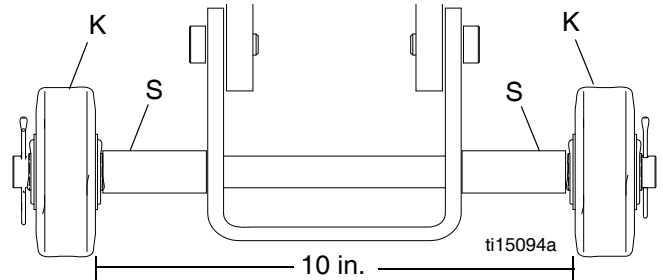

How to Level the Drum

To properly level the drum, GrindLazer must be resting on a flat level surface.

Depth Control Wheels Adjustment

- Make sure drum is properly installed (see **Drum Replacement**, page 7).
- Push down on handle bars, pull engagement lever, and lower drum into DOWN position.

- Loosen (but do not remove) three bolts (T) on Depth Control Wheel plate.

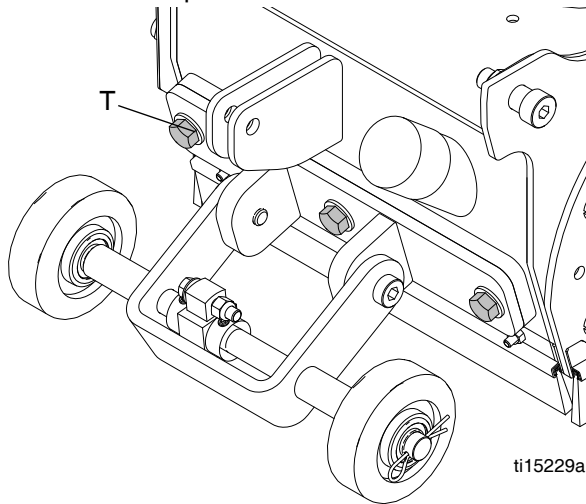

- Adjust plate until guide wheels lay flat on surface.
- Tighten three bolts (T) on plate.

Rear Axle Adjustment

If cut depth is uneven and the depth control wheels have already been properly adjusted (see **Depth Control Wheels Adjustment**, page 8), proceed with the following rear axle adjustment steps.

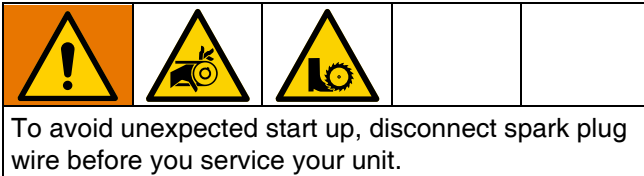

- Measure the cut depth discrepancy.
- Add equivalent washer thickness (to cut depth discrepancy) between the frame and rear axle on the side where it is cutting deep.
 - Loosen nuts on both sides of frame.
 - Add washer between axle and frame.
 - Torque both bolts to 12-15 ft-lbs.

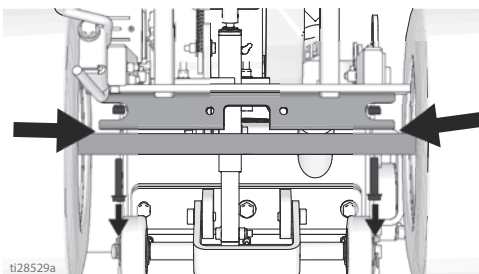

Dust Control

Vacuum Attachment

- If using a vacuum, attach vacuum hose to the Vacuum Port.

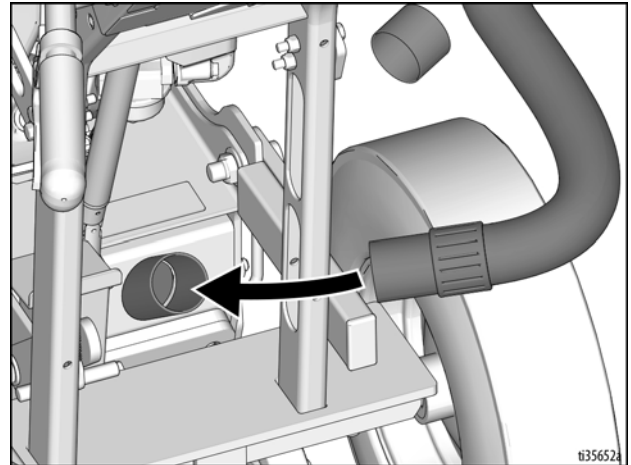

- Attach vacuum hose to the Inlet Port on the Cyclone Separator (optional) and/or vacuum.

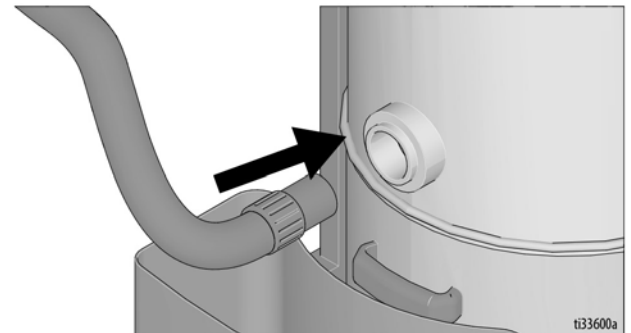

Water Hookup

If using water for dust control, hook up water hose to the fitting on top of drum housing. Turn water on.

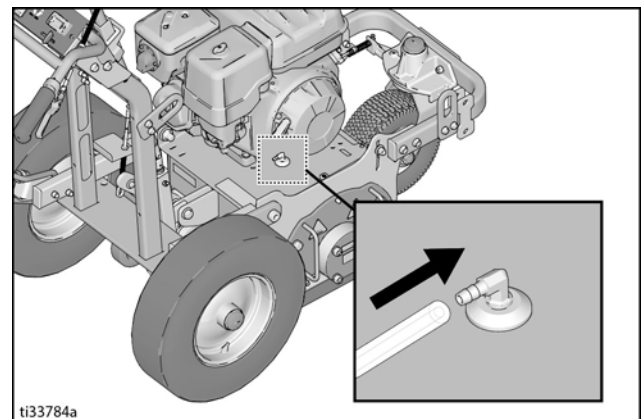

DCS Control (DCS Models only)

Buttons on the DCS Control have two functions, quick press and long press. Quick press refers to pressing the button and releasing the button quickly, while long press is pressing the button and holding the button for two or more seconds.

NOTE: "+" (plus) refers to above pavement surface. "-" (minus) refers to below pavement surface.

Run Screen

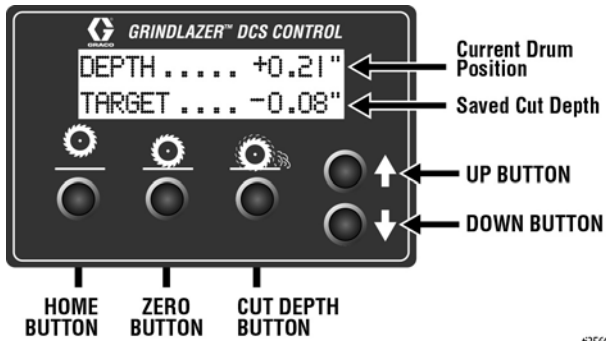

Home Button

Quick Press: Takes the drum to its highest position.



Long Press: Brings up Menu Screen.

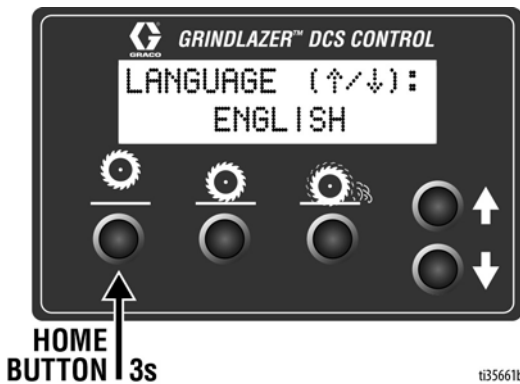

Zero Button

Quick Press: Takes the drum to the surface.



Long Press: Reprograms the zero point to the current drum position.



Cut Depth Button

Quick Press: Takes the drum to the Cut Depth Target.



ti35663a

Long Press:

- If at or above zero point: Opens new screen to select desired cut depth using up/down buttons.
 - To exit without saving, quick press the Cut Depth Button.
 - To exit with saving, long press the Cut Depth Button.
- If below zero point: Reprograms the Cut Depth Target to the current drum position.



ti35663b

Up Arrow Button*

Quick Press: Raises the drum by 0.01" (0.25mm, 10 mil).

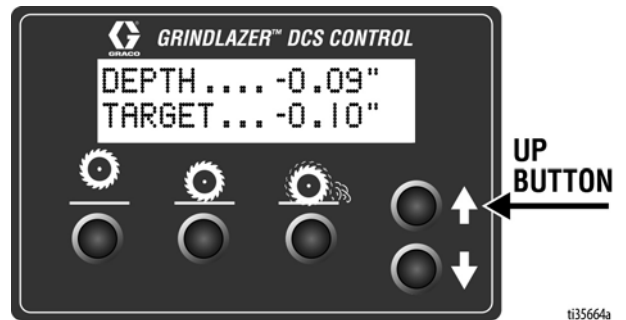

ti35664a

Long Press: Raises the drum to Home position.

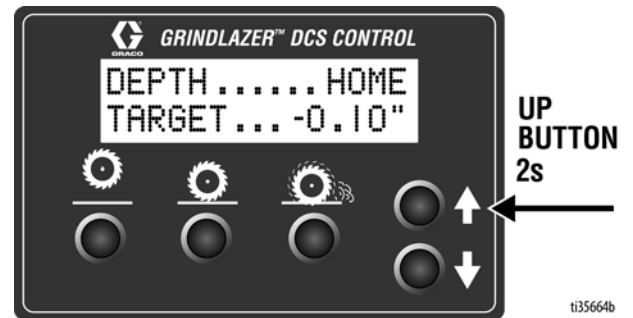

ti35664b

Down Arrow Button*

Quick Press: Lowers the drum by 0.01" (25mm, 10 mil).

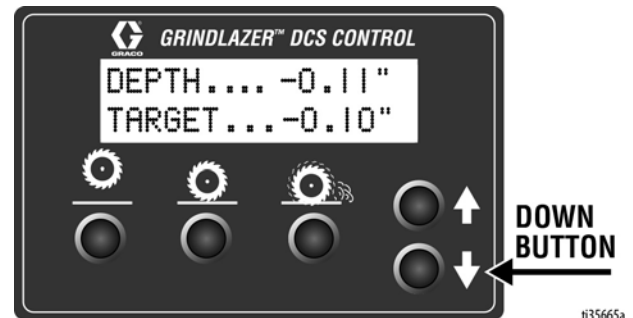

ti35665a

Long Press: Lowers the drum to Cut Depth Target.

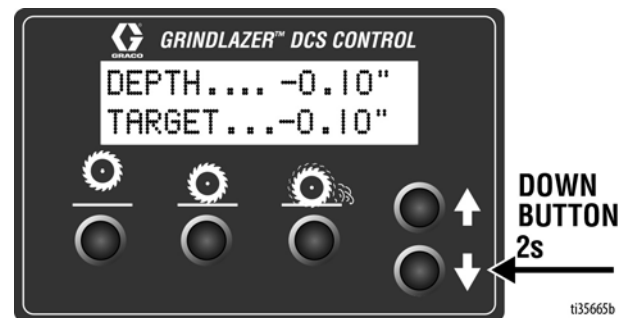

ti35665b

*Handlebar Rocker Switch has the same functions as Up and Down Arrow Buttons.

Menu Screens

To display the Menu Screens, hold down Home Button from the Run Screen. To save menu settings and return to Run Screen, hold down Home Button from any Menu Screen.

To cycle through selections in each Menu Screen, use Up and Down Arrow Buttons.

To advance to next Menu Screen, quick press the Home Button.

Menu Screen #1 - Language

Select your desired language (English, Spanish, French, German, or International Symbols).

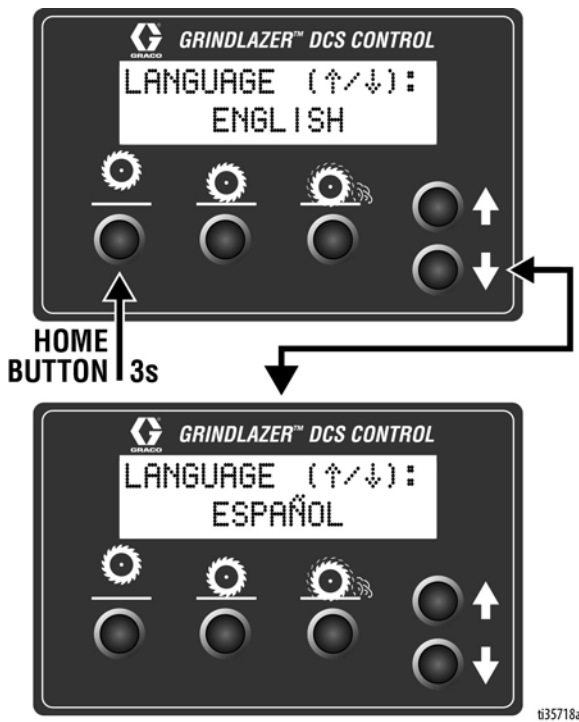

Menu Screen #2 - Units

Select your desired depth units (inches, millimeters, or mils).

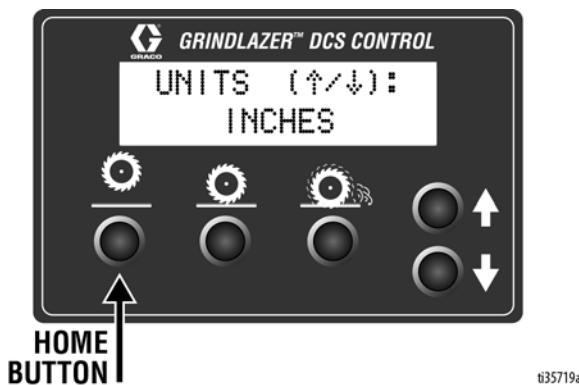

Menu Screen #3 - Model Select

Your GrindLazer model name can be found on the handlebar dashboard label. Select the model on the DCS Control which matches the model you have. This ensures accurate depth readings. Hold down Up or Down Arrow Buttons to cycle through models.

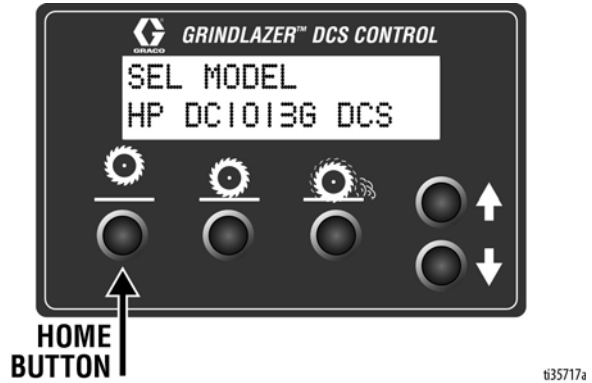

Menu Screen #4 - Software revision

Displays the revision of the software on the DCS Control.



Menu Screen #5 - Error Codes

Displays the most recent error code and the total number of times that error has occurred. Cycle through previous error codes using Up/Down Buttons.

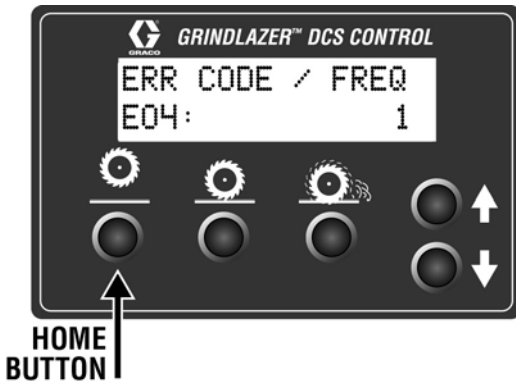

ti35721a

Error Codes

E04: High Voltage
 E05: High Motor Current
 E08: Low Voltage
 E09: Hall Sensor Error
 E12: High Current (short circuit)
 E31: Home Button Error
 E32: Zero Button Error
 E33: Cut Depth Button Error
 E34: Up Button Error
 E35: Down Button Error

To clear an error code that appears while on the Run Screen:

1. Turn DCS Power Switch OFF.
2. Address/Fix the issue.
3. Turn DCS Power Switch ON.

NOTE: See Repair Manual for more information on Error Codes and Troubleshooting.

Operation

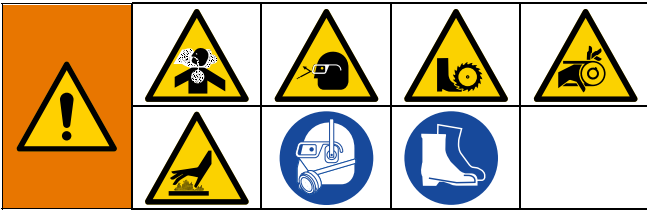

Do not start machine while drum is in contact with the ground. Doing so can cause the operator to lose control of the machine, resulting in property damage and/or personal injury.

Start-Up

Before starting engine, perform the following:

- Read and understand the engine manual.
- Make sure all guards are in place and secure.
- Make sure all mechanical fasteners are secure.
- Inspect for damage to engine and other exterior surfaces.
- Use correct cutters for each job. Make sure drum is balanced and the correct number, size and type of cutter wheels are being used. Make sure drum shaft is locked and secured.
- Inspect work area to locate any pipes, columns, deck inserts, or other objects protruding from work surface. Avoid these objects during operation.

Starting the Engine

1. Engage Rear Wheel Brake (G) to prevent GrindLazer from moving.

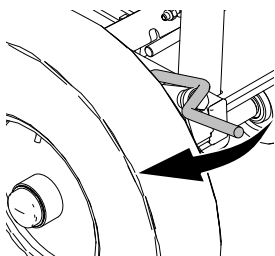

2. **25M994 & 25N659 Models Only:** Attach LineDriver to GrindLazer.

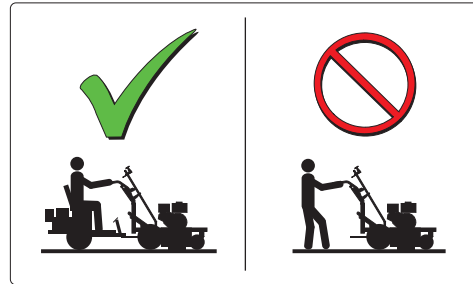

ti15089a

3. Push down on handle bars until drum is locked into UP position.

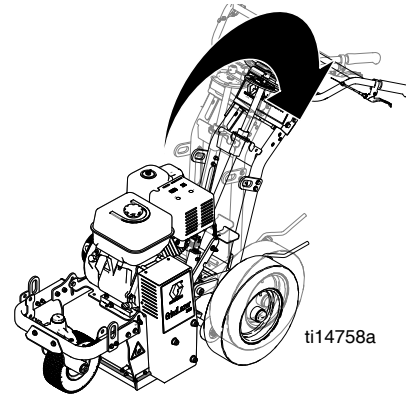

ti14758a

4. **DCS Models:** Turn DCS Control Power Switch ON (engine will not start if power switch is off). See **DCS Control (DCS Models only)**, page 10, for help setting up your DCS Control.

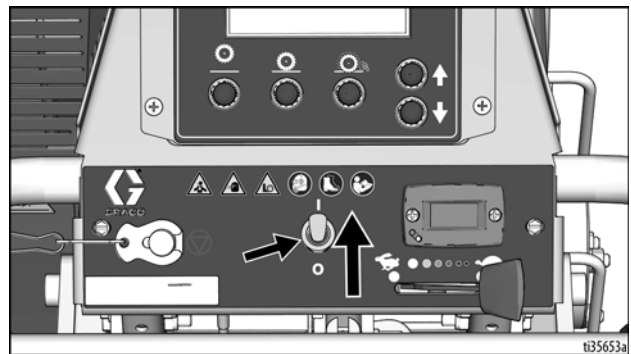

ti35653a

5. **Non-DCS Models:** Rotate Drum Adjustment Dial counterclockwise until a hard stop is felt.

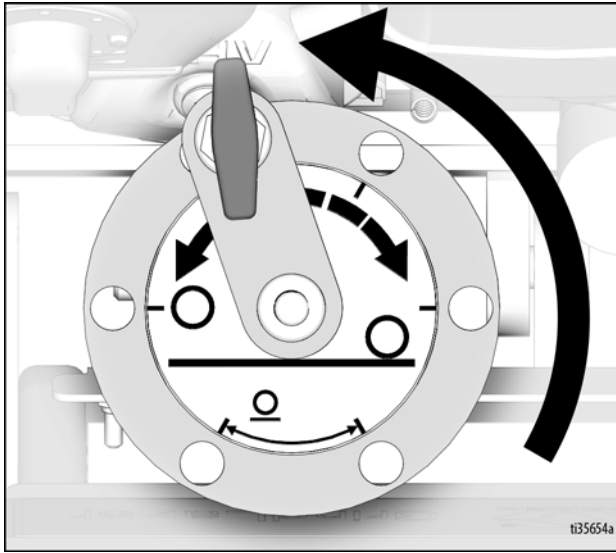

DCS Models: Press the Home Button on DCS Control.



6. **25M994 Model Only:** Make sure Power Switch (B) is in UP position.

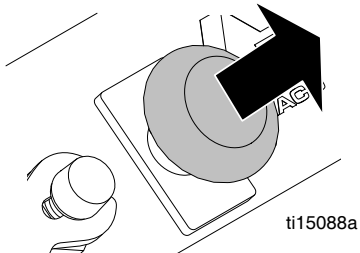

7. Start Engine:

- a. Move fuel valve to open.

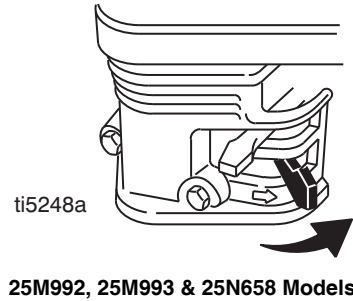

- b. Move choke to closed.



- c. Set Engine Power Switch (B) to ON.



- d. Pull starter cord, or turn key (electric start models only) to start engine.

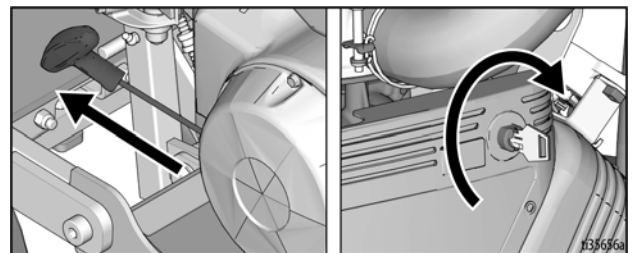

- e. After engine starts, move choke to open.

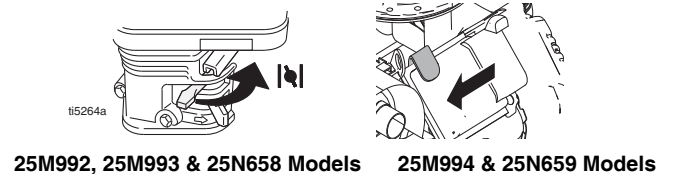

Cutting Material



Maintain a safe operating distance from other people in the work area. Avoid any pipes, columns, openings, or any other objects protruding from your work surface.

1. Start Engine, see page 15.
2. Turn vacuum on, if using a vacuum.
3. Connect Engine Kill Button Cord to operator.

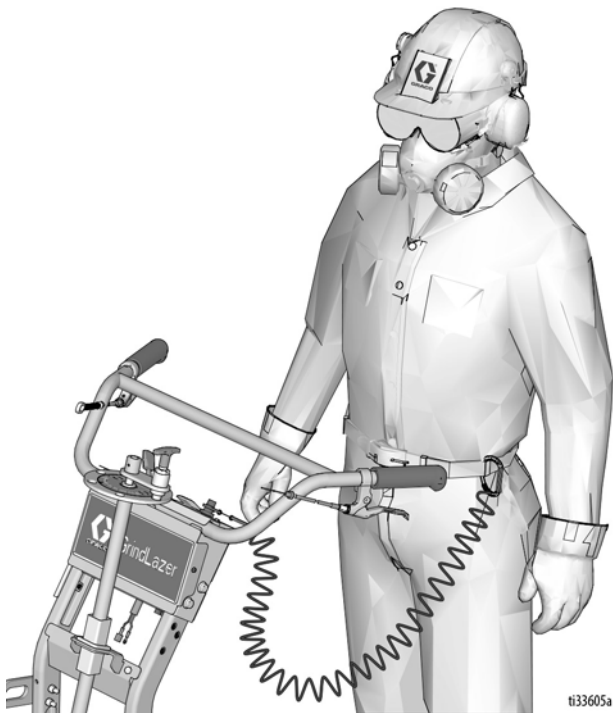

4. Slide Engine Throttle to desired setting.

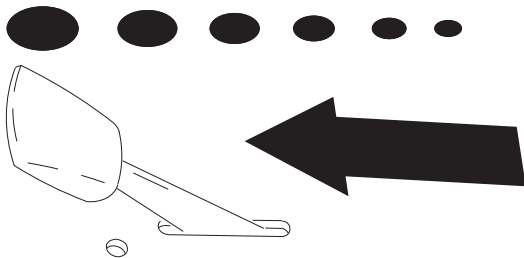

5. Push down on handle bars, pull engagement lever, and lower drum into DOWN position slowly.

NOTE: Dropping the drum to the down position quickly can cause damage to the drum and/or the DCS actuators.

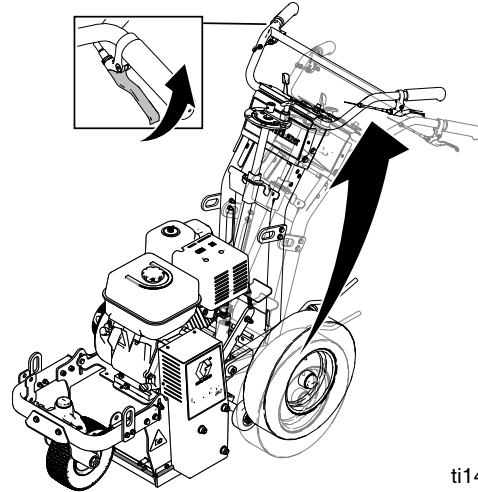

6. **Non-DCS Models:** Rotate Drum Adjustment Dial until drum comes into contact with surface and desired depth is reached.

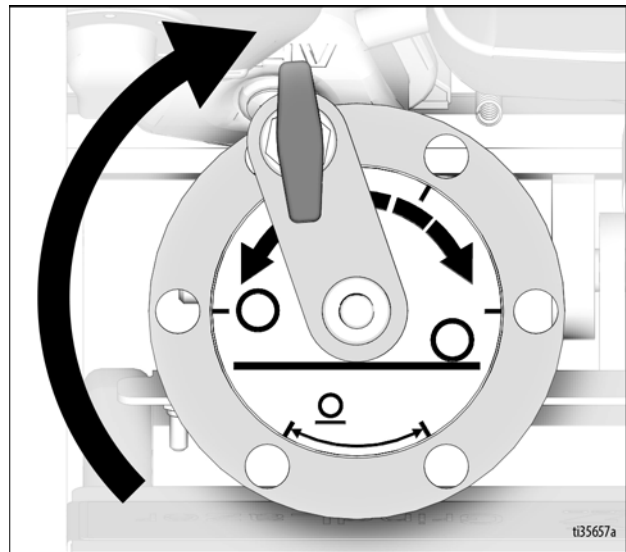

DCS Models: On the DCS Control, press the Cut Depth Button to lower the drum to the programmed cut depth. See **DCS Instructions**, page 19, for more details.



NOTE: Several test cuts may be needed to dial in desired cutting depth.

NOTE: On harder surfaces, it may be best to make several passes in increments of 1/32 in. (1mm) to get to the desired depth.

Cutting Drum Assemblies

BURN HAZARD				
Avoid touching or handling drum after use until it has completely cooled.				

Different drum configurations can be used for different applications.

Carbide Flail Cutter/Assembly

Gradually adjust depth down to remove marking line (minimal amount of paved surface should be removed).

Carbide Miller Cutter/Assembly

Best results for deep cuts are achieved by making several thin passes. A single pass should be no deeper than 1/32 in. (1mm) or damage to rods and cutters could occur.

Diamond Blade Assembly

Watch Depth Control Wheels (K) during operation; if wheels are rotating, proper depth is being achieved.

NOTICE
Diamond blades are designed to be cooled by air-flow around the blades. Lift blade out of cut every 10 to 15 seconds, then run at full speed for several seconds to prevent excessive heat build-up which could damage the blades.

Cutter and Drum Assemblies

- The engine should not labor. Run engine at full speed and adjust forward speed to fit the work being performed. Harder concrete surfaces will have to be cut at a slower pace than asphalt or other softer surfaces.

Non-DCS Models: Each increment on Drum Adjustment Dial (D) is 0.010 in. (0.25 mm) depth change of cutting drum.

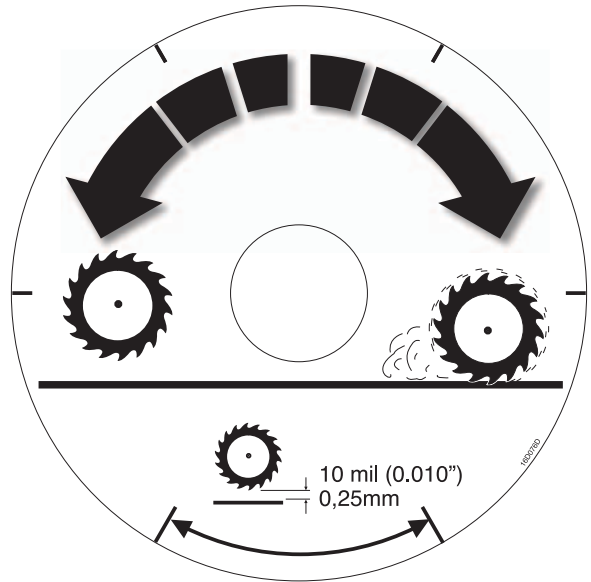

Stop Cutting Material

1. Push down on handle bars until drum is locked into UP position.

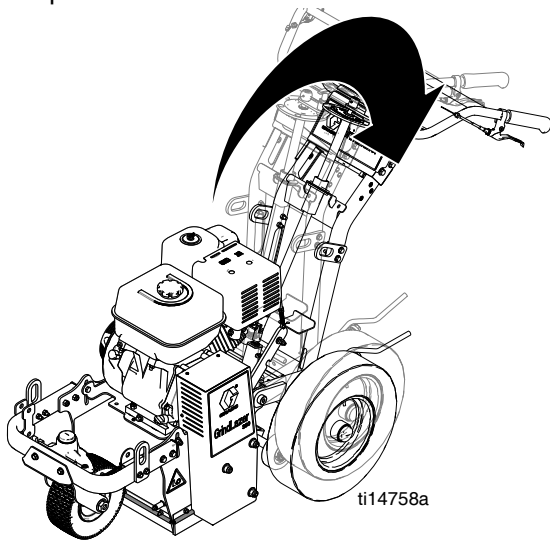

2. Slide Engine Throttle Lever (A) to low setting.

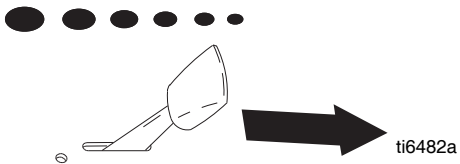

3. Turn Power Switch (B) OFF.

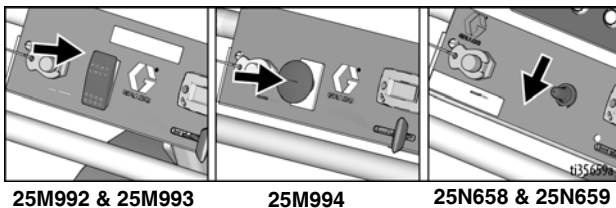

Clean Up

BURN HAZARD Avoid touching engine and drum after use until they have completely cooled.				

Clean the entire exterior of the machine after it has cooled at the end of each work day. Check for worn or damaged parts and perform any required **Maintenance**, page 21.

DCS Instructions

Each time the DCS Control is turned on, the DCS actuator will travel to the Home position.



Once the DCS Control finds Home, ensure the correct model is selected as well as your desired language and units. See **Menu Screens**, page 12, for instructions on changing these settings.

Set Zero Point:

Lower the Depth Control Wheels to the surface by using the Drum Engage Lever to unlatch the drum housing from the “up” position. With the engine on, lower the drum by pressing the Down Arrow Button until you hear the cutters make contact with the pavement surface. Hold down the Zero Button for 2 seconds. Your Zero Point has now been saved.

NOTE: The Cut Depth Target is based off of the Zero Point. Re-program the Zero Point if the drum is changed or worn.



Set Cut Depth Target:

Quick press the Zero Button to take the drum to the pavement surface. Set the Cut Depth Target by:

1. Quick pressing the Down Arrow Button as many times as needed to achieve your target. Then long press the Cut Depth Button to save your target.

NOTE: This method will lower the cutting drum into the pavement surface as you set your cut depth.

OR

2. From the Zero Point, long press the Cut Depth Button until a new screen pops up. Use the Down Arrow Button to enter your Cut Depth Target. Then long press the Cut Depth Button to save your target and return to the Run Screen.

NOTE: This method will keep the cutting drum stationary as you set your Cut Depth Target.



The DCS Control is now ready to grind/scarify. Long press down on the Handlebar Rocker Switch to lower the drum to your Cut Depth Target. Short press up or down on the switch to adjust your Cut Depth on the fly. When finished with your cut, long press up on the switch to raise the drum to the Home position.

NOTE: The Zero Point and Cut Depth are referenced from the Home position. Recalibrate your DCS Control periodically by pressing the Home button or long pressing up on the Handlebar Rocker Switch.

NOTE: Pressing any button while the drum is moving to Zero or Cut Depth will stop the command and halt the drum from moving any further up or down until another button is pressed.

Manual Height Adjustment

If the DCS Control is not usable (dead battery, etc.), the drum height can be adjusted using the Manual Height Adjustment feature.

1. Remove fuse from fuse holder near positive battery terminal. This will protect the battery from damage.

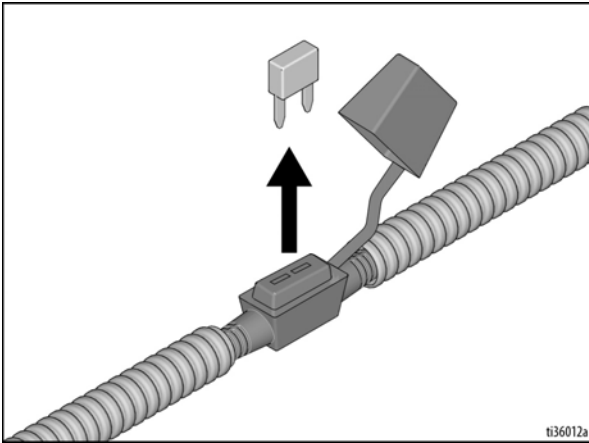

2. Use a 6mm hex key to remove the screw plug on the top of the linear actuator.

3. Insert 6mm hex key into the port the screw plug was removed from.

- One revolution of the hex key results in 1/8" (3mm, 125 mil) of adjustment at the cutter drum.
- Rotate clockwise to lower the drum; rotate counterclockwise to raise the drum. **Max rotation speed of 1 revolution per second. Do not use power tools in the Manual Height Adjustment port.**

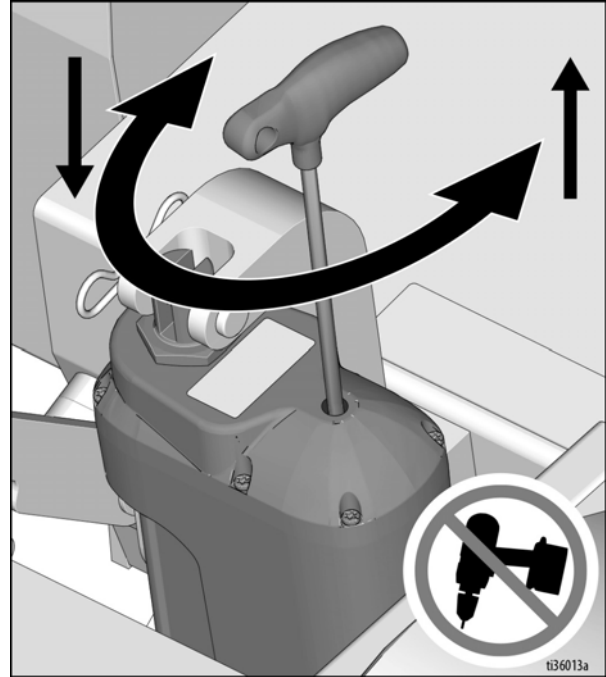

4. Once the desired depth is achieved, replace the screw plug in order to keep water and dust out.

Maintenance

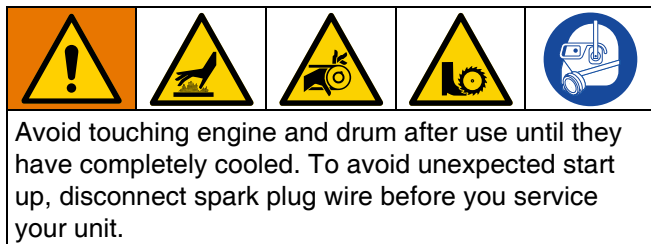

The following steps should be performed to maintain proper operation and sustain the life of the GrindLazer.

BEFORE OPERATION:

- Visually inspect the entire unit for damage or loose connections.
- Check engine oil (see engine manual).
- Check drum bushings and cutters.
- Check drum for uneven wear.
- Check for proper tire pressure.

DAILY:

- Insert and clean air filter element.
- Clean dust and debris from exterior of unit (do NOT use pressure washer or other high pressure cleaning equipment).
- Inspect dust skirts for damage. Repair or replace damaged skirts in order to ensure optimal dust and debris containment.
- If using water for dust control, clean out or replace water hose if clogged or damaged.
- Check engine oil level and fill as necessary.
- Check and fill gas tank.
- Remove air filter cover and clean element. Replace element if necessary. Replacement elements can be purchased from your local engine dealer.

AFTER THE FIRST 20 HOURS OF OPERATION:

- Drain engine oil and refill with clean oil. See engine manual for correct viscosity.

EVERY 40-50 HOURS OF OPERATION:

- Change engine oil (see engine manual).
- Grease wheel bearings.

AS REQUIRED:

- Check drive belt and tension and tighten or replace as needed. For additional information about engine maintenance, see Honda (270 and 390 models) or Briggs and Stratton (480 models) engine manual.

Caster Wheel Maintenance

EVERY MONTH:



- Grease wheel bearing.
- Check pin for wear. If pin is worn out there will be play in caster wheel. Reverse or replace pin as needed.
- Check caster wheel alignment as necessary. To align: loosen set screw, align wheel, and tighten screw.

Front Swivel Tire Alignment

1. Loosen cap screw.
2. Rotate front wheel fork left or right, as necessary, to straighten alignment.
3. Tighten cap screw. Push GrindLazer and let it roll with hands off of GrindLazer.

NOTE: If GrindLazer rolls right or left, repeat steps 1 - 3 until GrindLazer rolls straight.

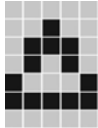
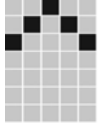
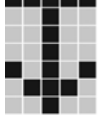
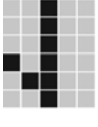
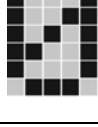
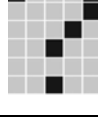
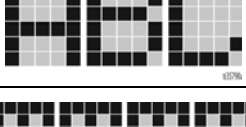
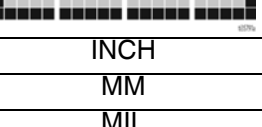
DCS Control Translations

English	Español	Français	Deutsche	International
FINDING HOME	ENCONTRANDO INICIO	TROUVER LE DÉBUT	START FINDEN	 035784a
HOME	INICIO	DÉBUT	START	 035785a
DEPTH	ALTURA	HAUTEUR	TIEFE	 035786a
TARGET	OBJETIVO	OBJECTIF	ZIEL	 035787a
ZERO	CERO	ZÉRO	NULL	 035788a
SEL MODEL	MODELO	MODELE	MODELL	 035789a
LANGUAGE	IDIOMA	LA LANGUE	SPRACHE	 035790a
UNITS	UNIDAD DE MEDIDA	UNITÉ DE MESURE	MAßEINHEIT	 035791a
INCHES	PULGADAS	POUCES	ZOLL	INCH
MILLIMETERS	MILIMETROS	MILLIMETRES	MILLIMETER	MM
MILS	MILS	MILS	MILS	MIL
SOFTWARE REV	SOFTWARE REV	REVUE SOFTWARE	SOFTWARE REV	 035792a
ERROR	ERROR	ERREUR	FEHLER	 035793a

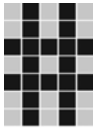
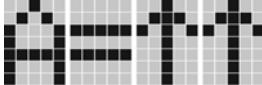
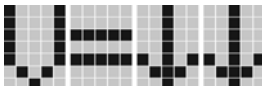
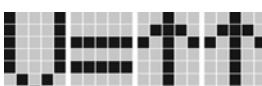
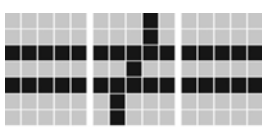
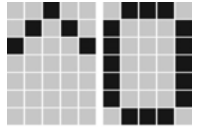
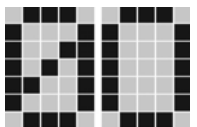
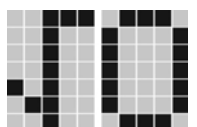
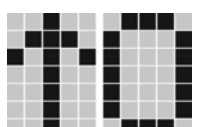
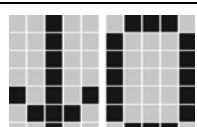
English	Español	Français	Deutsche	International
FREQUENCY	FRECUENCIA	FRÉQUENCE	ANZHAL	 835794
HIGH CURRENT	ALTA CORRIENTE	COURANT ÉLEVÉ	HOHER STROM	 835795
LOW VOLTAGE	BAJO VOLTAJE	BASSE TENSION	NIEDERSPANNUNG	 835796
HIGH VOLTAGE	ALTO VOLTAJE	HAUTE TENSION	HOCHSPANNUNG	 835797
HALL SENSORS	SENSORES DE HALL	CAPTEURS DE HALL	HALL-SENSOREN	 835798
HOME BUTTON	BOTÓN DE INICIO	BOUTON DE DÉBUT	START KNOPF	 835799
ZERO BUTTON	BOTÓN CERO	BOUTON ZÉRO	NULLTASTE	 835800
CUT BUTTON	BOTÓN DE CORTAR	BOUTON DE COUPE	SCHNITT TASTE	 835801
UP BUTTON	BOTÓN ARRIBA	BOUTON HAUT	NACH OBEN TASTE	 835802
DOWN BUTTON	BOTÓN DE ABAJO	BOUTON BAS	NACH UNTEN TASTE	 835803

Technical Data

GrindLazer HP DC89 G (Model 25M992)		
Dimensions		
	Unpackaged	Packaged
Height in./cm:	46 (116.8)	50.5 (128.3)
Width in./cm:	28 (71.1)	37 (94.0)
Length in.cm:	62 (157.5)	73 (185.4)
Weight lb/kg:	300 (136)	400 (181)
Noise (dBa)		
Sound Power per ISO 3744:	107.3	
Sound Pressure measured at 3.1 feet (1m):	91.6	
Vibration (m/sec²) per ISO 3744		
Without LineDriver:	7.9	
With LineDriver:	8.3	
Power Rating (HorsePower) per SAE J1349		
8.0 @ 3600 rpm		
Maximum storage time	5 years	
Maximum lifetime	10 years	
Power efficiency factor	200 ground meters per liter fuel	
GrindLazer HP DC1013 (Model 25M993)		
Dimensions		
	Unpackaged	Packaged
Height in./cm:	46 (116.8)	50.5 (128.3)
Width in./cm:	28 (71.1)	37 (94.0)
Length in.cm:	62 (157.5)	73 (185.4)
Weight lb/kg:	310 (141)	410 (186)
Noise (dBa)		
Sound Power per ISO 3744:	109.3	
Sound Pressure measured at 3.1 feet (1m):	93.6	
Vibration (m/sec²) per ISO 3744		
Without LineDriver:	7.5	
With LineDriver:	5.9	
Power Rating (HorsePower) per SAE J1349		
11.0 @ 3600 rpm		

GrindLazer HP DC1021 G (Model 25M994)		
Dimensions		
	Unpackaged	Packaged
Height in./cm:	46 (116.8)	50.5 (128.3)
Width in./cm:	28 (71.1)	37 (94.0)
Length in.cm:	62 (157.5)	73 (185.4)
Weight lb/kg:	365 (165)	465 (211)
Noise (dBa)		
Sound Power per ISO 3744:	108.6	
Sound Pressure measured at 3.1 feet (1m):	92.1	
Vibration (m/sec²) per ISO 3744		
With LineDriver:	4.9	
Power Rating (HorsePower) per SAE J1349		
21.0 @ 3600 rpm		
GrindLazer HP DC1013 G DCS (Model 25N658)		
Dimensions		
	Unpackaged	Packaged
Height in./cm:	46 (116.8)	50.5 (128.3)
Width in./cm:	28 (71.1)	37 (94.0)
Length in.cm:	62 (157.5)	73 (185.4)
Weight lb/kg:	355 (161)	455 (206)
Noise (dBa)		
Sound Power per ISO 3744:	109.3	
Sound Pressure measured at 3.1 feet (1m):	93.6	
Vibration (m/sec²) per ISO 3744		
Without LineDriver:	7.5	
With LineDriver:	5.9	
Power Rating (HorsePower) per SAE J1349		
11.0 @ 3600 rpm		
GrindLazer HP DC1021 G DCS (Model 25N659)		
Dimensions		
	Unpackaged	Packaged
Height in./cm:	46 (116.8)	50.5 (128.3)
Width in./cm:	28 (71.1)	37 (94.0)
Length in.cm:	62 (157.5)	73 (185.4)
Weight lb/kg:	385 (175)	485 (220)
Noise (dBa)		
Sound Power per ISO 3744:	108.6	
Sound Pressure measured at 3.1 feet (1m):	92.1	
Vibration (m/sec²) per ISO 3744		
With LineDriver:	4.9	
Power Rating (HorsePower) per SAE J1349		
21.0 @ 3600 rpm		

Graco Standard Warranty

Graco warrants all equipment referenced in this document which is manufactured by Graco and bearing its name to be free from defects in material and workmanship on the date of sale to the original purchaser for use. With the exception of any special, extended, or limited warranty published by Graco, Graco will, for a period of twelve months from the date of sale, repair or replace any part of the equipment determined by Graco to be defective. This warranty applies only when the equipment is installed, operated and maintained in accordance with Graco's written recommendations.

This warranty does not cover, and Graco shall not be liable for general wear and tear, or any malfunction, damage or wear caused by faulty installation, misapplication, abrasion, corrosion, inadequate or improper maintenance, negligence, accident, tampering, or substitution of non-Graco component parts. Nor shall Graco be liable for malfunction, damage or wear caused by the incompatibility of Graco equipment with structures, accessories, equipment or materials not supplied by Graco, or the improper design, manufacture, installation, operation or maintenance of structures, accessories, equipment or materials not supplied by Graco.

This warranty is conditioned upon the prepaid return of the equipment claimed to be defective to an authorized Graco distributor for verification of the claimed defect. If the claimed defect is verified, Graco will repair or replace free of charge any defective parts. The equipment will be returned to the original purchaser transportation prepaid. If inspection of the equipment does not disclose any defect in material or workmanship, repairs will be made at a reasonable charge, which charges may include the costs of parts, labor, and transportation.

THIS WARRANTY IS EXCLUSIVE, AND IS IN LIEU OF ANY OTHER WARRANTIES, EXPRESS OR IMPLIED, INCLUDING BUT NOT LIMITED TO WARRANTY OF MERCHANTABILITY OR WARRANTY OF FITNESS FOR A PARTICULAR PURPOSE.

Graco's sole obligation and buyer's sole remedy for any breach of warranty shall be as set forth above. The buyer agrees that no other remedy (including, but not limited to, incidental or consequential damages for lost profits, lost sales, injury to person or property, or any other incidental or consequential loss) shall be available. Any action for breach of warranty must be brought within two (2) years of the date of sale.

GRACO MAKES NO WARRANTY, AND DISCLAIMS ALL IMPLIED WARRANTIES OF MERCHANTABILITY AND FITNESS FOR A PARTICULAR PURPOSE, IN CONNECTION WITH ACCESSORIES, EQUIPMENT, MATERIALS OR COMPONENTS SOLD BUT NOT MANUFACTURED BY GRACO. These items sold, but not manufactured by Graco (such as electric motors, switches, hose, etc.), are subject to the warranty, if any, of their manufacturer. Graco will provide purchaser with reasonable assistance in making any claim for breach of these warranties.

In no event will Graco be liable for indirect, incidental, special or consequential damages resulting from Graco supplying equipment hereunder, or the furnishing, performance, or use of any products or other goods sold hereto, whether due to a breach of contract, breach of warranty, the negligence of Graco, or otherwise.

FOR GRACO CANADA CUSTOMERS

The Parties acknowledge that they have required that the present document, as well as all documents, notices and legal proceedings entered into, given or instituted pursuant hereto or relating directly or indirectly hereto, be drawn up in English. Les parties reconnaissent avoir convenu que la rédaction du présente document sera en Anglais, ainsi que tous documents, avis et procédures judiciaires exécutés, donnés ou intentés, à la suite de ou en rapport, directement ou indirectement, avec les procédures concernées.

Graco Information

TO PLACE AN ORDER, contact your rae-prostores.com or call [1-877-275-7550](tel:1-877-275-7550)



All written and visual data contained in this document reflects the latest product information available at the time of publication. Graco reserves the right to make changes at any time without notice.

Original instructions. This manual contains English. MM 3A5918

Graco Headquarters: Minneapolis

International Offices: Belgium, China, Japan, Korea

GRACO INC. AND SUBSIDIARIES • P.O. BOX 1441 • MINNEAPOLIS MN 55440-1441 • USA
Copyright 2018, Graco Inc. All Graco manufacturing locations are registered to ISO 9001.

www.graco.com
Revision C, February 2020