

REPAIR - RÉPARATION - REPARACIONES - REPARO



309053J

EN/PT/FR/ES

295ST, 395/455/495ST PRO™, STX™, SPX™

Displacement Pump Bomba de deslocamento Pompe volumétrique Bomba de desplazamiento

*3300 psi (228 bar, 23 MPa) Maximum Working Pressure
Pressão máxima de trabalho de 3300 psi (228 bar, 23 MPa)
Pression maximale de service 3300 lb/po² (228 bar, 23 MPa)
Presión máxima de operación 3300 psi (228 bar, 23 MPa)*

Model 246426

STX™
SPX™



Important Safety Instructions

Read all warnings and instructions in this manual.
Save these instructions.

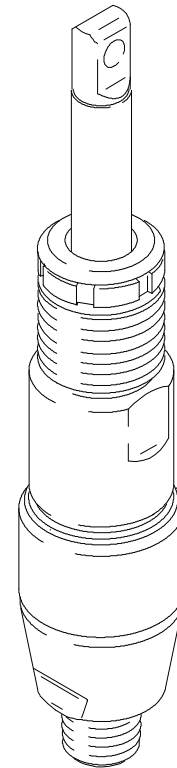

05963

[return to rae-products](#)

GRACO INC. P.O. BOX 1441 MINNEAPOLIS, MN 55440-1441

©COPYRIGHT 1999, GRACO INC.

Graco Inc. is registered to I.S. EN ISO 9001

⚠ WARNING

Fire and explosion hazard: Solvent and paint fumes can ignite or explode.

To help prevent a fire and explosion:

- Use only in an extremely well ventilated area.
- Eliminate all ignition sources; such as pilot lights, cigarettes and static arcs from plastic drop cloths. Do not plug or unplug power cords or turn lights on or off in spray area.
- Ground Sprayer, object being sprayed, paint and solvent pails.
- Hold gun firmly to side of grounded pail when triggering into pail.
- Use only conductive airless paint hose.
- Do not use 1,1,1-trichloroethane, methylene chloride, other halogenated hydrocarbon solvents or fluids containing such solvents in pressurized aluminum equipment. Such use could result in a chemical reaction, with the possibility of explosion.

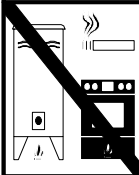

⚠ ADVERTÊNCIA

Perigo de incêndio e explosão: os solventes e os vapores da pintura poderão explodir ou incendiar.

Para ajudar a evitar incêndio e explosão:

- Utilize unicamente em áreas extremamente bem ventiladas.
- Elimine todas as fontes de ignição, tais como luzes piloto, cigarros e arcos de estática resultantes dos plásticos de proteção. Não ligue nem desligue os cabos de alimentação ou as luzes numa área de pulverização.
- Ponha em contato com a terra o pulverizador, o objeto a ser pulverizado, e os baldes de tinta e de solventes.
- Segure a pistola firmemente de encontro ao lado do balde em contato com a terra, quando estiver descarregando para dentro do mesmo.
- Utilize somente tubos flexíveis condutores para pintura a alta pressão.
- Não utilize 1,1,1-tricloroetano, cloreto de metileno, outros solventes de hidrocarbonetos halogenados ou líquidos contendo tais solventes em equipamento de alumínio pressurizado. Tal utilização poderá resultar numa reação química, com possibilidade de explosão.

Fluid injection and high pressure hazard: High pressure spray or leaks can inject fluid into the body.

To help prevent injection, always:

- Engage trigger safety latch when not spraying.
- Keep clear of nozzle and leaks.
- Never spray without a tip guard.
- Do **PRESSURE RELIEF** if you stop spraying or begin servicing sprayer.
- Do not use components rated less than sprayer *Maximum Working Pressure*.
- Never allow children to use this unit.

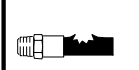

If high pressure fluid pierces your skin, the injury might look like "just a cut". But it is a serious wound! Get immediate medical attention.

Perigo de injeção de líquidos à alta pressão: a pulverização ou vazamentos à alta pressão podem injetar líquido no corpo.

Para ajudar a evitar injeção de líquido, faça sempre o seguinte:

- Engate o trinco de segurança do gatilho quando não estiver pulverizando.
- Mantenha-se afastado dos bocais e locais onde há vazamentos.
- Nunca pulverize sem que haja uma proteção na extremidade.
- **ALIVIE A PRESSÃO** quando parar de pulverizar e antes de iniciar a manutenção do pulverizador.
- Não utilize componentes com uma classificação inferior à do pulverizador *Pressão Máxima de Trabalho*.
- Nunca permita que crianças utilizem esta unidade.

Se o líquido a alta pressão penetrar na sua pele, o ferimento poderá parecer "simplesmente um corte". Mas é um ferimento grave! Procure o médico imediatamente.

⚠ MISE EN GARDE

Danger d'incendie et d'explosion : les gaz de solvant et de peinture peuvent s'enflammer ou exploser.

Pour éviter les risques d'incendie et d'explosion :

- N'utiliser l'appareil que dans une zone extrêmement bien aérée.
- Éliminer toute source d'inflammation ; telle que veilleuses, cigarettes et arcs d'électricité statique créés par les toiles de peintre en plastique. Ne pas brancher et débrancher de cordons électriques, ou allumer et éteindre des lumières dans la zone de pulvérisation.
- Mettre à la terre le pulvérisateur, l'objet à pulvériser ainsi que les seaux de peinture et de solvants.
- Tenir le pistolet fermement contre la paroi d'un seau mis à la terre lorsqu'on pulvérise dans le seau.
- N'utiliser qu'un flexible pour peinture pulvérisée sans air.
- Ne jamais utiliser de trichloroéthane 1,1,1, de chlorure de méthylène, d'autres solvants à base d'hydrocarbures halogénés, ni de produits contenant de tels solvants dans un équipement sous pression en aluminium. Cela pourrait provoquer une réaction chimique avec risque d'explosion.

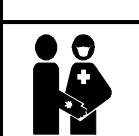
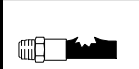
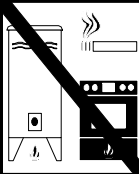

Danger d'injection de fluide et haute pression : la pulvérisation sous haute pression ou les fuites peuvent injecter des fluides dans le corps.

Pour éviter les risques d'injection, toujours :

- Bloquer le loquet de sécurité de la gâchette à la fin de la pulvérisation.
- Se tenir loin de la buse et des fuites.
- Ne jamais pulvériser sans anti-gouttes.
- **DÉCHARGER LA PRESSÃO** à la fin de la pulvérisation ou avant de réparer le pulvérisateur.
- Ne pas utiliser de composants dont la pression nominale est inférieure à la *pression maximale de service du système*.
- Ne jamais permettre aux enfants d'utiliser cet appareil.

Si un fluide haute pression perce la peau, la blessure peut paraître comme une "simple coupure". Mais il s'agit bien d'une lésion grave! Consulter immédiatement un médecin.

⚠ ADVERTENCIA

Peligro de incendio o explosión: Los gases de los disolventes y de la pintura pueden inflamarse o provocar una explosión.

Para prevenir incendios y explosiones:

- Use únicamente en un área muy bien ventilada.
- Suprima todas las fuentes de ignición; como luces piloto, cigarrillos y arcos estáticos de carpetas plásticas para protección contra pintura. No enchufe ni desenchufe cables de alimentación ni apague ni encienda las luces en un área de pulverización.
- Ponga a tierra el pulverizador, el objeto que recibe el chorro pulverizado, las cubetas de pintura y disolvente.
- Sostenga firmemente la pistola a un lado de la cubeta puesta a tierra cuando dispare dentro de ella.
- Use solamente mangueras para pintura conductora sin aire.
- No utilice nunca tricloroetano-1,1,1, cloruro de metileno ni otros disolventes a base de hidrocarburos halógenos o fluidos que contengan dichos disolventes en un equipo a presión de aluminio. El uso de estas sustancias puede provocar una intensa reacción química, con riesgos de explosión.

Peligro de inyección de fluido y alta presión: por la pulverización o las filtraciones a alta presión se pueden inyectar fluidos en el organismo.

Para prevenir la inyección en la piel, siempre:

- Enganche el seguro del gatillo cuando no use el pulverizador.
- No se acerque a la boquilla ni a las filtraciones.
- Nunca aplique fluido pulverizado sin un guardaboquilla.
- Realice el **ALIVIO DE PRESSÃO** si deja de pulverizar fluido o repara el pulverizador.
- No use componentes de capacidad nominal inferior a la *presión máxima de operación del pulverizador*.
- No permita que niños usen esta unidad.

Si fluido de alta presión le penetra la piel, la lesión podría parecer "sólo un corte". ¡Es una lesión seria! Consulte de inmediato al médico.

PRESSURE RELIEF / ALÍVIO DE PRESSÃO DÉCHARGE DE PRESSION / ALIVIO DE LA PRESIÓN



Follow 1-5 when you stop spraying.
Siga os passos de 1-5 quando parar de pulverizar.
Suivre les étapes 1 à 5 lorsqu'on arrête de pulvériser.
Siga los pasos 1-5 cuando deje de usar el pulverizador.

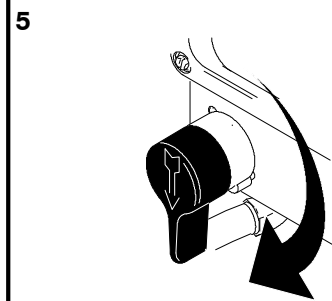
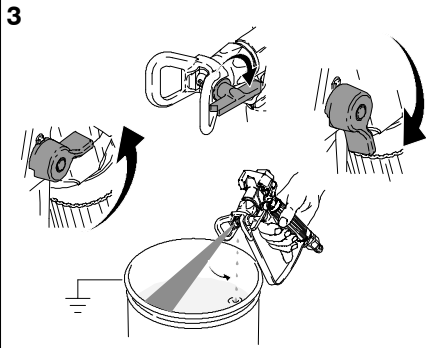
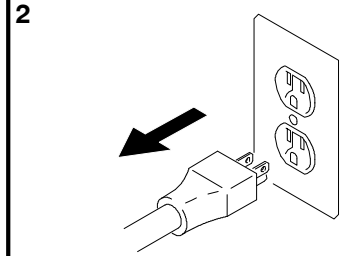
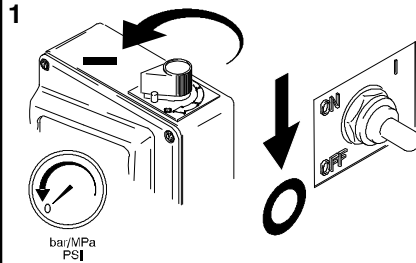

DISASSEMBLE / DESMONTAGEM DÉMONTAGE / DESARMAR

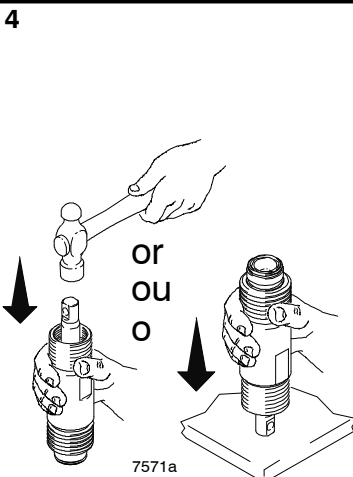
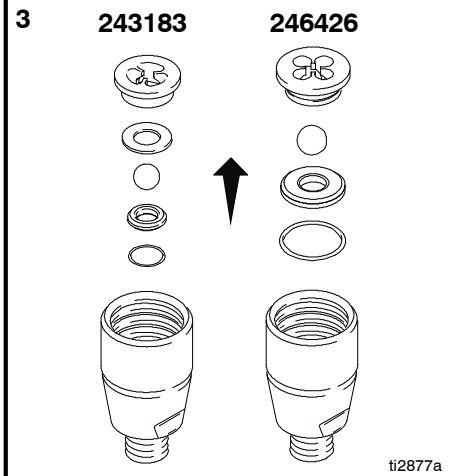
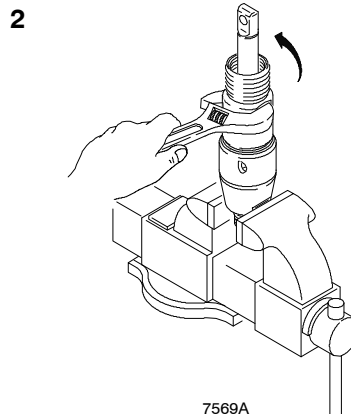
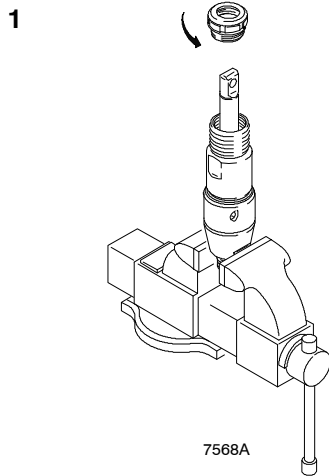

COMPONENT DAMAGE HAZARD
PERIGO DE DANOS NOS COMPONENTES
RISQUE D'ENDOMMAGEMENT DE COMPOSANTS
PELIGRO DE DAÑO A COMPONENTES

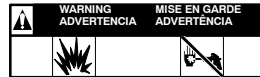

Do not clean piston valve threads. Cleaning piston valve threads could destroy thread locking patch and cause piston valve to come loose during operation, causing pump damage and possible serious injury.
No limpie los hilos de la válvula de pistones. Al limpiar los hilos de la válvula de pistones podría destruir la placa de trabadura de hilos y causar que la válvula de pistones se suelte durante el funcionamiento y se produzcan daños en la bomba y posibles lesiones serias.
Ne pas nettoyer les filets du clapet piston. Un tel nettoyage pourrait détruire l'enduit frein des filets et causer la dislocation du clapet piston en fonctionnement, entraînant ainsi l'endommagement de la pompe et des blessures graves.
No limpie los hilos de la válvula de pistones. Al limpiar los hilos de la válvula de pistones podría destruir la placa de trabadura de hilos y causar que la válvula de pistones se suelte durante el funcionamiento y se produzcan daños en la bomba y posibles lesiones serias.

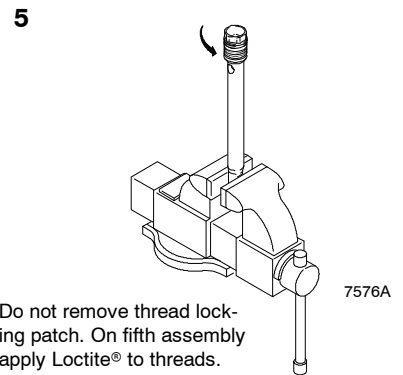

Do not remove thread locking patch. On fifth assembly apply Loctite® to threads.
Não retire o embutimento de travar roscas. Na quinta unidade, aplique Loctite® nas roscas.
Ne pas enlever l'enduit frein des filets. Au cinquième assemblage, appliquer du Loctite® sur les filets.
No quite la placa de trabadura de hilos. Aplique Loctite® a los hilos en el quinto conjunto.

DISASSEMBLE / DESMONTAGEM DÉMONTAGE / DESARMAR

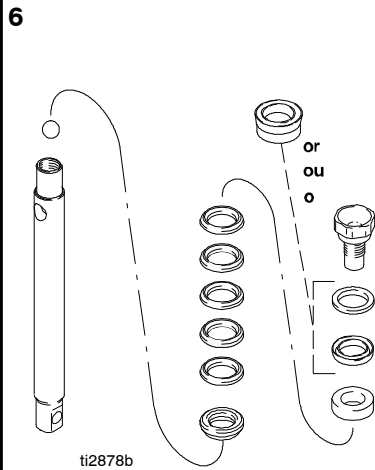

ti2878b

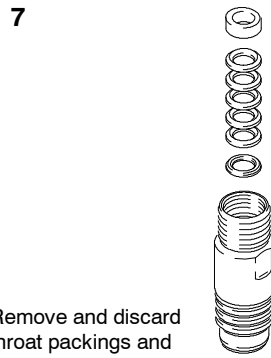

7573B

Remove and discard throat packings and glands from cylinder.

Retire e jogue fora as gaxetas da garganta e as buchas do cilindro.

Enlever du cylindre les garnitures de collet et les presse-garnitures et les jeter.

Retire y elimine las empaquetaduras y casquillos del cilindro.

ASSEMBLE / MONTAGEM ASSEMBLAGE / ARMAR

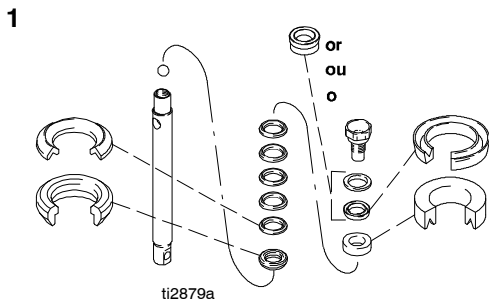

ti2879a

Soak leather packings in SAE 30W oil for 1 hour before assembly.

Mergulhe as gaxetas de couro em óleo SAE 30W por 1 hora antes da montagem.

Avant d'effectuer l'assemblage, tremper les garnitures en cuir dans de l'huile SAE 30W pendant une heure.

Remoje las empaquetaduras de couro en aceite SAE 30W durante 1 hora antes de armar.

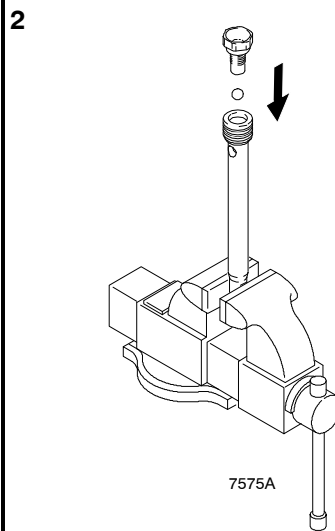

7575A

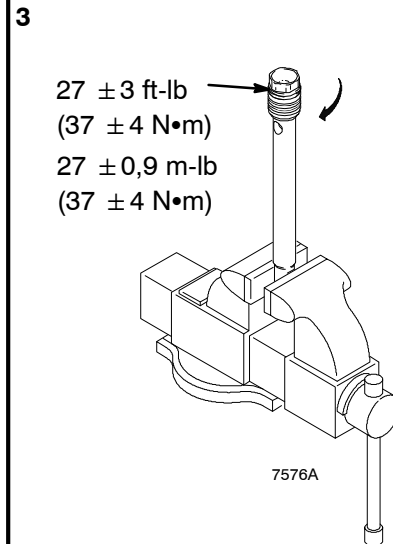

27 ± 3 ft-lb
(37 ± 4 N•m)

$27 \pm 0,9$ m-lb
(37 ± 4 N•m)

7576A

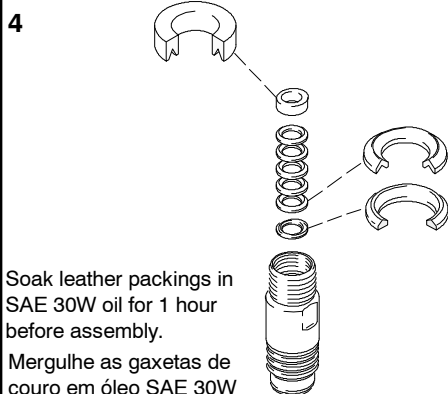

Soak leather packings in SAE 30W oil for 1 hour before assembly.

Mergulhe as gaxetas de couro em óleo SAE 30W por 1 hora antes da montagem.

Avant d'effectuer l'assemblage, tremper les garnitures en cuir dans de l'huile SAE 30W pendant une heure.

Enjuague las empaquetaduras de couro en aceite SAE 30W durante 1 hora antes de armar.

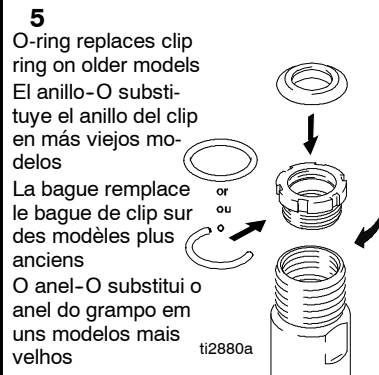

ti2880a

O-ring replaces clip ring on older models
El anillo-O substituye el anillo del clip en más viejos modelos

La bague remplace le bague de clip sur des modèles plus anciens

O anel-O substitui o anel do grampo em uns modelos mais velhos

Loosely install packing nut onto cylinder.

Instale folgadoamente a porca de empanque no cilindro. Visser l'écrou de presse-garniture sur le cylindre sans le serrer.

Instale, sin apretar, la tuerca prensaestopas en el cilindro.

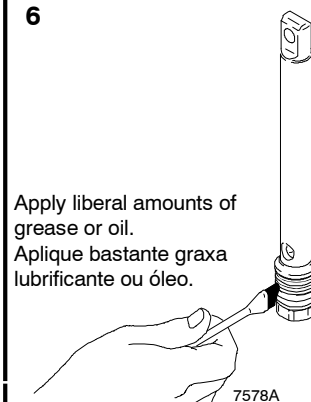

7578A

Apply liberal amounts of grease or oil.
Aplique bastante graxa lubrificante ou óleo.

Appliquer généreusement de la graisse ou de l'huile.
Aplique grasa o aceite a discreción.

ASSEMBLE / MONTAGEM ASSEMBLAGE / ARMAR

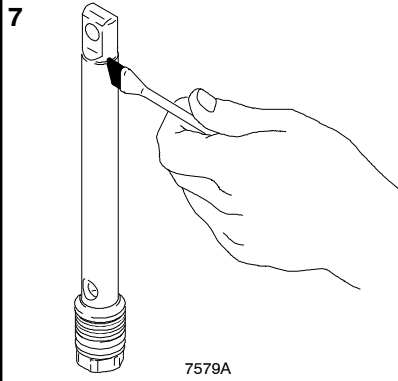

Grease top two inches of piston rod.
 Aplique graxa lubrificante em cerca de 5 cm da parte superior da haste do êmbolo.
 Lubrifier sur deux pouces de hauteur la partie supérieure de la tige du piston.
 Engrase dos pulgadas de la parte superior del pistón.

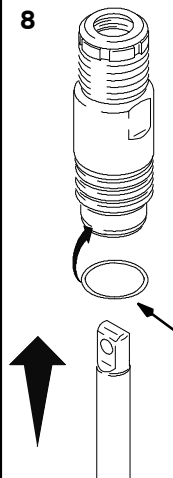

Grease and place on O.D. ring groove
 Lubrifique e coloque na ranhura do anel de vedação.
 Lubrifier et placer sur la rainure annulaire extérieure.
 Engrase y coloque en la ranura para aro del D.E.

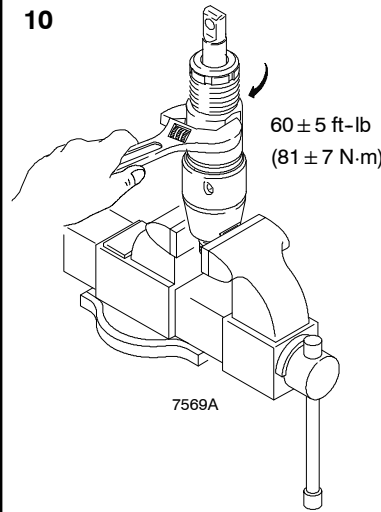
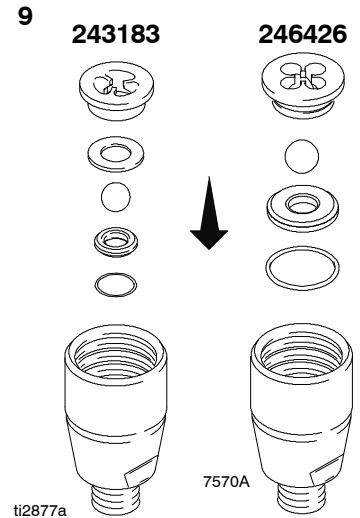

60 ± 5 ft-lb
 (81 ± 7 N·m)

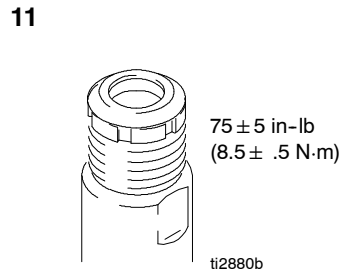

75 ± 5 in-lb
 ($8.5 \pm .5$ N·m)

* Or additional 1/2 turn from hand tight
 * O vuelta adicional del 1/2 de la mano firmemente
 * Ou tour additionnel de 1/2 de main fortément
 * Ou volta adicional de 1/2 da mão firmemente

12 Storage / Armazenamento Stockage / Almacenamiento

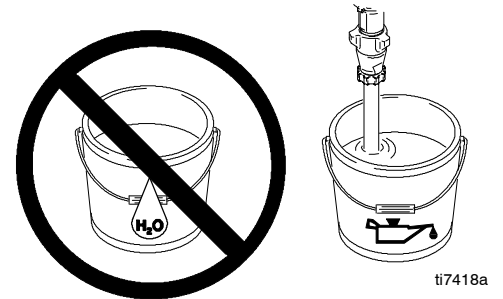

Flush with oil before storage
 Nivele com óleo antes do armazenamento
 Rincez avec de l'huile avant stockage
 Limpie con aceite antes de almacenaje

THROAT PACKING ADJUSTMENT/AJUSTE DAS GAXETAS DA GARGANTA/AJUSTEMENT DE LA GARNITURE DE COLLET/AJUSTE DE LA EMPAQUETADURA DE LA GARGANTA

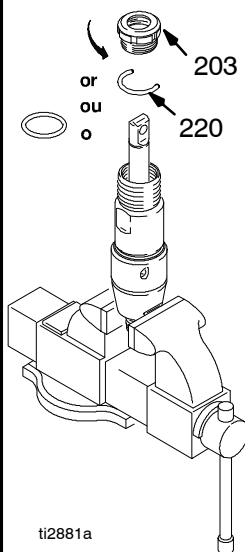

Remove throat nut spacer (220) when pump packings begin to leak after much use. Then tighten packing nut down until leakage stops or lessens. This allows approximately 100 gallons of additional operation before a repacking is required.

O-ring replaces clip ring on older pumps; packing nut can be tightened without o-ring removal.

Retire o espaçador da porca da garganta (220) assim que as gaxetas da bomba começarem a vazar após uma utilização intensiva. Depois, aperte a porca de vedação até que o vazamento pare ou diminua. Isto permitirá uma utilização adicional de cerca de 378 litros antes que seja necessária uma substituição.

El anillo-O (220) substituye el anillo del clip en más viejos modelos. La tuerca del embalaje se puede apretar sin retiro del anillo-O.

Enlever la cale (220) d'écrou de collet lorsqu'on décèle une fuite par la garniture de la pompe après usage intense. Serrer ensuite le presse-garniture jusqu'à l'arrêt ou la diminution de la fuite. Ceci permettra la pulvérisation sur 378 litres additionnelles avant de devoir remplacer la garniture.

La bague (220) remplace la bague de clip sur des modèles plus anciens. L'écrou d'emballage peut être serré sans déplacement de bague.

Retire el espaciador de la tuerca de la garganta (220) cuando haya filtraciones por las empaquetaduras después del uso excesivo. Luego apriete la tuerca de la empaquetadura hasta que la filtración se detenga o se reduzca. Ello permite aproximadamente 378 litros adicionales de funcionamiento antes de que sea necesario cambiar las empaquetaduras.

O anel-O (220) substitui o anel do grampo em uns modelos mais velhos. Aporca da embalagem pode ser apertada sem remoção do anel-O.

Parts / Peças / Pièces / Piezas - 246426

STX, SPX (826032)

Ref No.	Part No.	Description	Qty.
201	243174	ROD, piston	1
202	180656	SEAL, throat	1
203	193047	NUT, packing	1
204*	176757	GLAND, female, throat	1
205*	176754	GLAND, male, throat	1
206	243176	CYLINDER, pump	1
207*	105444	BALL, sst, 0.3125 in.	1
208*	195129	GLAND, male, piston	1
209*	180073	GLAND, female, piston	1
210*	196759	GUIDE, piston	1
212	243181	VALVE, piston	1
213†	15C011	GUIDE, ball	1
215†	246429	KIT, seat, carbide includes 217 and 218	1
216	15B874	VALVE, intake (foot)	1
217*†	15B112	PACKING, o-ring (0.941 in. OD)	1
218*†	105445	BALL, sst, 0.5000 in.	1
219*	17V093	PACKING, o-ring	1
220*	117459	O-RING	1
221*	176755	V-PACKING, leather, throat	2
222*	192710	V-PACKING, throat, V-Max™ UHMWPE, blue	3
223*	176749	V-PACKING, leather, piston	2
224*	192712	V-PACKING, piston V-Max™ UHMWPE, blue	3
225	162453	NIPPLE, 1/4 npsm x 1/4 npt	1

* Also included in Kit 244194

† Also included in Kit 246429

* Também incluído no Kit 244194

† Também incluído no Kit 246429

* Inclus aussi dans la trousse 244194

† Inclus aussi dans la trousse 246429

* También incluida en Kit 244194

† También incluida en Kit 246429

Technical Data/Dados

Técnicos/Fiche

technique/Datos técnicos

Maximum working pressure / Pressão máxima de trabalho de
Pression maximale de service /
Presión máxima de operación

3300 psi (228 bar, 23 MPa)
3 300 lb/po² (228 bar, 23 MPa)

Fluid inlet size / Dimensões da entrada de líquido

Dia. de l'orifice d'entrée / Tamaño de la entrada de fluido ... 1/2 npt(m)

Fluid outlet size / Dimensões da saída de líquido

Dia. de l'orifice de sortie / Tamaño de la salida de fluido ... 1/4 npt(f)

Wetted parts stainless steel, PTFE, leather,
polyurethane, zinc-plated carbon steel, tungsten carbide,
chrome plating, UHMWPE, acetal, polyethylene, nylon

Peças lubrificadas aço inoxidável, PTFE, couro,
poliuretano, aço carbono zincado, carboneto de
tungstênio, cromagem, UHMWPE, acetal, polietileno

Pièces en contact avec du liquide acier inoxydable et en
PTFE, cuir, polyuréthane, acier carbone zingué,
carbure de tungstène, plaquage au chrome,
UHMWPE, acetal, polyéthylène

Piezas húmedas acero inoxidable, PTFE,
cuero, poliuretano, acero al carbono enchapado en cinc,
carburo de tungsteno, enchape en cromo,
UHMWPE, polietileno acetal,

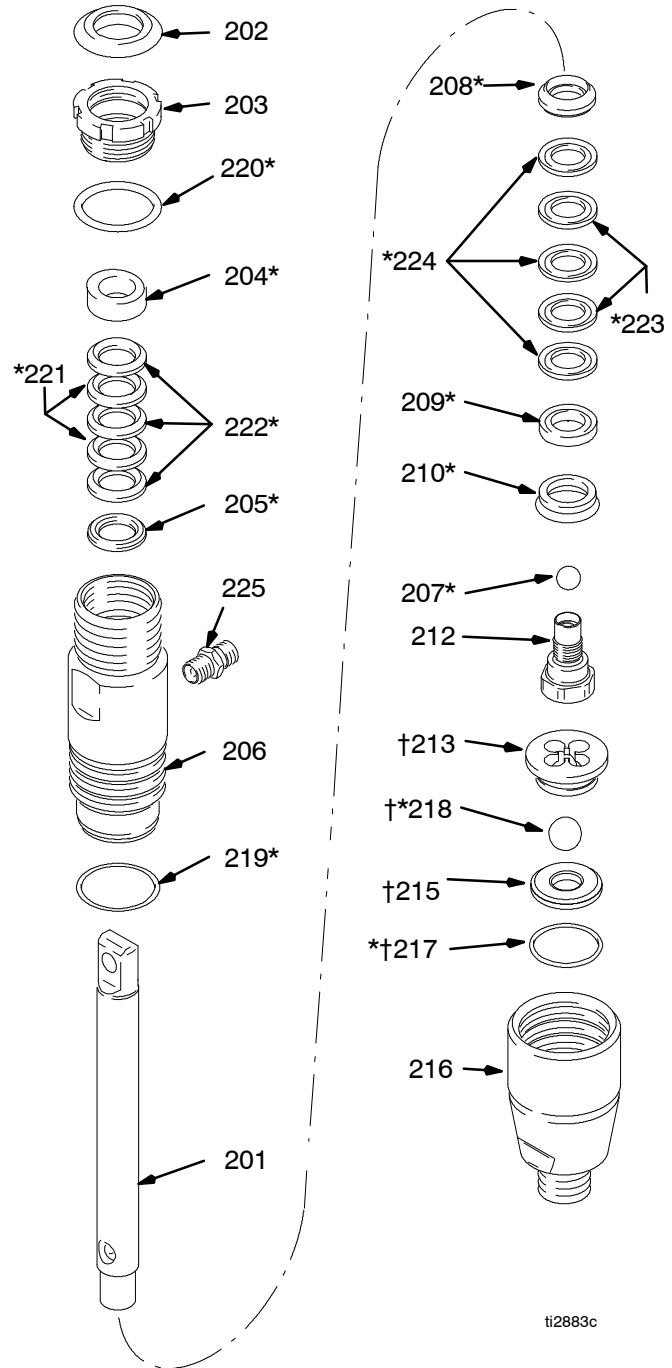

ti2883c

NOTE: Loctite® is a registered trademark of the Loctite Company.

NOTA: Loctite® é uma marca registrada da Loctite Company.

REMARQUE: Loctite® est une marque déposée de la compagnie Loctite.

NOTA: Loctite® es una marca registrada de Loctite Company.

Graco Standard Warranty

Garantia Standard da Graco

Garantie standard de Graco

Garantía estándar Graco

Graco warrants all equipment referenced in this document which is manufactured by Graco and bearing its name to be free from defects in material and workmanship on the date of sale to the original purchaser for use. With the exception of any special, extended, or limited warranty published by Graco, Graco will, for a period of twelve months from the date of sale, repair or replace any part of the equipment determined by Graco to be defective. This warranty applies only when the equipment is installed, operated and maintained in accordance with Graco's written recommendations.

This warranty does not cover, and Graco shall not be liable for general wear and tear, or any malfunction, damage or wear caused by faulty installation, misapplication, abrasion, corrosion, inadequate or improper maintenance, negligence, accident, tampering, or substitution of non-Graco component parts. Nor shall Graco be liable for malfunction, damage or wear caused by the incompatibility of Graco equipment with structures, accessories, equipment or materials not supplied by Graco, or the improper design, manufacture, installation, operation or maintenance of structures, accessories, equipment or materials not supplied by Graco.

This warranty is conditioned upon the prepaid return of the equipment claimed to be defective to an authorized Graco distributor for verification of the claimed defect. If the claimed defect is verified, Graco will repair or replace free of charge any defective parts. The equipment will be returned to the original purchaser transportation prepaid. If inspection of the equipment does not disclose any defect in material or workmanship, repairs will be made at a reasonable charge, which charges may include the costs of parts, labor, and transportation.

THIS WARRANTY IS EXCLUSIVE, AND IS IN LIEU OF ANY OTHER WARRANTIES, EXPRESS OR IMPLIED, INCLUDING BUT NOT LIMITED TO WARRANTY OF MERCHANTABILITY OR WARRANTY OF FITNESS FOR A PARTICULAR PURPOSE.

Graco's sole obligation and buyer's sole remedy for any breach of warranty shall be as set forth above. The buyer agrees that no other remedy (including, but not limited to, incidental or consequential damages for lost profits, lost sales, injury to person or property, or any other incidental or consequential loss) shall be available. Any action for breach of warranty must be brought within two (2) years of the date of sale.

GRACO MAKES NO WARRANTY, AND DISCLAIMS ALL IMPLIED WARRANTIES OF MERCHANTABILITY AND FITNESS FOR A PARTICULAR PURPOSE, IN CONNECTION WITH ACCESSORIES, EQUIPMENT, MATERIALS OR COMPONENTS SOLD BUT NOT MANUFACTURED BY GRACO. These items sold, but not manufactured by Graco (such as electric motors, switches, hose, etc.), are subject to the warranty, if any, of their manufacturer. Graco will provide purchaser with reasonable assistance in making any claim for breach of these warranties.

In no event will Graco be liable for indirect, incidental, special or consequential damages resulting from Graco supplying equipment hereunder, or the furnishing, performance, or use of any products or other goods sold hereto, whether due to a breach of contract, breach of warranty, the negligence of Graco, or otherwise.

FOR GRACO BRAZILIAN/CANADIAN/COLUMBIAN CUSTOMERS

The Parties acknowledge that they have required that the present document, as well as all documents, notices and legal proceedings entered into, given or instituted pursuant hereto or relating directly or indirectly hereto, be drawn up in English.

PARA CLIENTES BRASILEIROS DA GRACO

As partes confirmam que solicitaram que o presente documento, assim como todos os demais documentos, notas e processos legais inseridos, atribuídos ou instituídos de acordo com o mesmo ou relacionados direta ou indiretamente com este documento, sejam redigidos em inglês.

POUR LES CLIENTS DE GRACO AU CANADA

Les parties conviennent qu'elles ont exigé que le présent document, ainsi que tous les autres documents, avis et poursuites judiciaires intervenus, accordés ou institués en relation directe ou indirecte aux termes cités ci-après soient rédigés en anglais.

PARA CLIENTES COLOMBIANOS GRACO

Las partes reconocen que han exigido que el presente documento, como asimismo toda la documentación, notificaciones o procedimientos legales en que se incurra, o bien se instituyan en cumplimiento con el presente documento o en relación directa o indirecta con el mismo, sean redactados en inglés.

ADDITIONAL WARRANTY COVERAGE / COBERTURA DE GARANTIA ADICIONAL GARANTIE PROLONGÉE / COBERTURA ADICIONAL DE LA GARANTÍA

Graco does provide extended warranty and wear warranty for products described in the "Graco Contractor Equipment Warranty Program".

A Graco fornece prorrogação de garantia e garantia de desgaste para os produtos descritos no "Graco Contractor Equipment Warranty Program" (Programa de garantia de equipamento do empreiteiro da Graco).

Graco n'offre pas de garantie prolongée ni de garantie contre l'usure pour les produits décrits dans le "Programme de garantie des équipements pour entrepreneur de Graco".

Graco ofrece una garantía extendida y una garantía de desgaste para los productos consignados en el "Programa de Garantía de Equipo Graco para Contratistas".

Graco Information

TO PLACE AN ORDER, find us at rae-prostores.com or call us [1-877-275-7550](tel:1-877-275-7550)



All written and visual data contained in this document reflects the latest product information available at the time of publication. Graco reserves the right to make changes at any time without notice.

Todos os dados escritos e visuais contidos neste documento refletem as mais recentes informações sobre o produto disponíveis na época da publicação. A Graco reserva-se o direito de efetuar alterações em qualquer momento sem aviso prévio.

Toute information écrite et graphique incluse dans ce document reflète les caractéristiques les plus récentes des produits au moment d'aller sous presse. Graco se réserve le droit d'apporter des modifications en tout temps sans avis.

Toda el material escrito y visual contenido en este documento refleja la información de producto más reciente manejada al momento de la publicación. Graco se reserva el derecho de introducir cambios en cualquier momento sin aviso.

This manual contains English, Portuguese, French, and Spanish. MM 309053.

Sales Offices: Minneapolis

Foreign Offices: Belgium, Korea, China, Japan

Escritórios de Vendas: Minneapolis

Escritórios Estrangeiros: Bélgica, Coréia, China, Japão

Bureaux de vente : Minneapolis

International : Belgique, Corée, Chine, Japon

Oficinas de venta: Minneapolis

Oficinas en el exterior: Bélgica, Corea, China, Japón

GRACO INC. P.O. BOX 1441 MINNEAPOLIS, MN 55440-1441

<http://www.graco.com>

309053 September 1999, Revised June 2019

309053 Setembro de 1999, Révisé Junho 2019

309053 Septembre 1999, Revisado Juin 2019

309053 Septiembre de 1999, Revisado Junio 2019